



THE MARYLAND-NATIONAL CAPITAL
Park and Planning Commission

COMMISSION MEETING

November 18, 2020

10:00 a.m. – 11:00 p.m.

via teleconference

and live-streamed by

**Prince George's
Parks and Recreation Administration**
6600 Kenilworth Avenue
Riverdale, Maryland 20737

This page intentionally left blank.

MARYLAND-NATIONAL CAPITAL PARK AND PLANNING COMMISSION
AMENDED MEETING AGENDA
Wednesday, November 18, 2020

Via videoconference, and live-streamed by
The Prince George’s County Department of Parks and Recreation

10:00 a.m. – 11 a.m.

		<u>ACTION</u>	
		Motion	Second
1.	Approval of Commission Agenda (10:00 a.m.)	(+*) Page 1	
2.	Approval of Commission Minutes (10:05 a.m.)		
	a) Open Session – October 21, 2020	(+*) Page 3	
	b) Closed Session – October 21, 2020	(++*)	
	c) Special Session – October 22, 2020	(+*) Page 9	
3.	General Announcements (10:05 a.m.)		
	a) Commission-wide Service Awards Luncheon Honoring Employees with 25 or more years of service		
	b) National American Indian Heritage Month (Maryland American Indian Heritage Day Nov 27)		
	c) American Lung Cancer Awareness Month & Pancreatic Cancer Awareness Month		
	d) “Great American Smoke Out” Nov 19		
	e) Bereaved Siblings Month		
	f) Caregivers Month		
	g) National Adoption Month		
	h) 100 th Anniversary of Armistice Day		
	i) Military Family Appreciation Month		
	j) Thanksgiving & Employee Appreciation Day Holidays		
	k) Upcoming Prince George’s County Department of Parks and Recreation Annual Winter Festival of Lights at Watkins Park		
	l) Upcoming Montgomery Parks Department Winder Garden Walk-Through Holiday Light Display at Brookside Gardens		
	m) Upcoming One-Commission Holiday Event		
	n) Diversity Council Openings for 2021		
4.	Committee Minutes/Board Reports (For Information Only) (10:15 a.m.)		
	a) Executive Committee Meeting – Open Session – November 4, 2020	(+) Page 11	
	b) Executive Committee Meeting – Closed Session – November 4, 2020	(++)	
	c) Employees’ Retirement System Board of Trustees Regular Meeting – November 3, 2020	(+) Page 13	
5.	Action and Presentation Items (10:15 a.m.)		
	a) Resolution #20-27 Recommendation to Approve an Employer Contribution in the Amount of \$26,174,744 for Fiscal Year 2022 (Rose/Cranna/Nelson)	(+*) Page 17	
<i>Pursuant to Maryland General Provisions Article of the Annotated Code of Maryland, Section 3-305(b) (7) & (9), a closed session is proposed to consult with counsel for legal advice, conduct collective bargaining discussions and consider matters that relate to negotiation.</i>			
6.	Closed Session Item (10:30 a.m.)		
	a) CIO Quarterly Update (Chilet)	(++)	

Open Session resumes

7. **Officers' Reports (10:45 a.m.)**

Executive Director's Report

a) Late Evaluation Report, October 2020 (For Information Only) (+) Page 39

Secretary Treasurer

b) 4th Quarter Investment Report (For Information Only) (+) Page 41

General Counsel

c) 1. Litigation Report (For Information Only) (+) Page 47
2. Legislative Update (H)

(+) Attachment

(++) Commissioners Only

(*) Vote

(H) Handout

(LD) Late Delivery



THE MARYLAND-NATIONAL CAPITAL PARK AND PLANNING COMMISSION

6611 Kenilworth Avenue • Riverdale, Maryland 20737

Commission Meeting
Open Session Minutes
October 21, 2020

The Maryland-National Capital Park and Planning Commission met via videoconference with the Chair initiating the meeting at the Wheaton Headquarters Auditorium in Wheaton, Maryland. The meeting was broadcast by the Department of Parks and Recreation, Prince George’s County.

PRESENT

Montgomery County Commissioners

Casey Anderson, Chair
Gerald Cichy
Tina Patterson
Partap Verma (departed at 11:40 a.m.)

Prince George’s County Commissioners

Elizabeth M. Hewlett, Vice-Chair
Dorothy Bailey
William Doerner
Manuel Geraldo

NOT PRESENT

Natali Fani-Gonzalez

A. Shuanise Washington

CA called meeting to order at 10:02 a.m.

ITEM 1 APPROVAL OF COMMISSION AGENDA

Corrected date for July 15 minutes
ACTION: Motion of Vice-Chair Hewlett to approve the agenda
Seconded by Commissioner Geraldo
8 approved the motion

ITEM 2 APPROVAL OF COMMISSION MINUTES

Open Session – September 16, 2020
Closed Session – September 16, 2020
Open and Closed Session – July 15, 2020*
ACTION: Motion of Commissioner Vice Chair Hewlett to approve the minutes
Seconded by Commissioner Geraldo
8 approved the motion
**Minutes erroneously approved as July 16, 2020 during the September Meeting*

ITEM 3 GENERAL ANNOUNCEMENTS

- a) Breast Cancer Awareness Month
- b) National Pregnancy and Infancy Loss Awareness Month
- c) National AIDS Awareness Month
- d) Hiring People with Disabilities Month
- e) National Domestic Violence Awareness Month
- f) National Stop Bullying Month

- g) Italian American, German American and Polish American Heritage Month
- h) National Down Syndrome Awareness
- i) Vice Chair Hewlett wished Chair Anderson and Commissioner Fani-Gonzalez happy birthdays

ITEM 4 COMMITTEE MINUTES/BOARD REPORTS (For Information Only)

- a) Executive Committee – Open Session October 7, 2020
- b) Executive Committee – Closed Session October 7, 2020

Chair Anderson asked for a motion to enter closed session at 10:05 a.m. Vice Chair Hewlett moved; Commissioner Geraldo seconded. The motion was approved by all 8 Commissioners present for the vote.

Pursuant to Maryland General Provisions Article of the Annotated Code of Maryland, Section 3-305(b) (7) & (9), a closed session is proposed to consult with counsel for legal advice and conduct collective bargaining discussions.

There being no further business to discuss in closed session, the meeting resumed in open session at 11:48 a.m.

ITEM 6 ACTION AND PRESENTATION ITEMS

- a) Park Police Resolutions

- 1. Resolution 20-23 Ratification of the tentative Agreement for 3-year collective bargaining contract with The Fraternal Order of Police (FOP) (Chiang-Smith/Bennett)
- 2. Resolution 20-24 Approval of Fiscal Year 2021 Cost of Living Adjustment and Pass-Through of Other Terms for Command Officers and Candidates (Chiang-Smith/Bennett)

ACTION: Motion of Commissioner Geraldo to approve Resolutions 20-23 and 20-24
 Seconded by Commissioner Patterson
 7 approved the motion (Verma absent for vote)

- b) Consideration of item 5b. Memorandum of Understanding (MOU) between the United States Attorney’s Office for the District of Columbia, the Metropolitan Police Department of Washington, DC and the Maryland-National Capital Park and Planning Commission (Gardner/Dickerson)

ACTION: Motion of Vice Chair Hewlett to approve the MOU
 Seconded by Commissioner Patterson
 7 approved the motion (Verma absent for vote)

- c) Resolution 20-25 In Support of Question A, and in Opposition to Question B for the 2020 General Election in Montgomery County (Gardner)

ACTION: Motion of Commissioner Geraldo to approve Resolution 20-25
 Seconded by Vice Chair Hewlett
 7 approved the motion (Verma absent for vote)

- d) Resolution 20-22 Appointment of Gerald Cichy to the Board of Trustees of the Employees' Retirement System (Rose)

ACTION: Motion of Vice Chair Hewlett to approve Resolution 20-22
Seconded by Commissioner Patterson
7 approved the motion (Verma absent for vote)

- e) Health Insurance Rate Changes for the Municipal and County Government Employees Organization (MCGEO) Collective Bargaining Unit (Spencer/McDonald)

ACTION: Item not taken

- f) I-495 / I-270 Managed Lanes Briefing and Update (Rubin/Borden)

Special Project Manager Rubin recommended the Commission authorize the Chair and Vice-Chair, designated officers, staff and/or counsel to transmit correspondence as necessary and appropriated to:

- (a) Express the substantive and technical comments developed by Commission staff detailing the deficiencies in the Draft Environmental Impact Statement (DEIS) issued by the Federal Highway Administration (FHWA) and Maryland Department of Transportation's State Highway Administration (MDOT SHA) in connection with the I-495 and I-270 Managed Lanes Study (Project); and,
- (b) Express the substantive and technical comments developed by Commission staff as reasons for denying any joint permit application (JPA) made by FHWA and MDOT SHA to the U.S. Army Corps of Engineers (USA-COE) and the Maryland Department of Environment (MDE) for alternation of a floodplain waterway tidal or nontidal wetland in Maryland.

Comments and concerns for the Joint Permit Application include:

- MDOT SHA and FHWA have eliminated alternatives from detailed study, including the MD 200 Diversion Alternative, transportation demand management and transit alternatives, that are practicable and would be much less damaging to the environment.
- The limits of disturbance (LOD) in the DEIS do not adequately address the likely impacts of the project on aquatic resources.
- The JPA and supporting documents fail to adequately address required mitigation.
- The JPA and supporting documents do not comply with Section 106 of the National Historic Preservation Act.
- The Clean Water Act Section 401 Water Quality Certification and the Coastal Zone Management Act (CMZA), Section 307 consistency should be reviewed prior to the FEIS.

Comments and Concerns for the Draft Environmental Impact Study:

- Insufficient Accounting for the ICC.
- LOD Modifications after FEIS and ROD.
- Making Parks Whole Again.
- Adherence to the Capper-Cramton Act.
- Social Equity.
- Alternative Modes of Travel.
- Non-auto driver mode share (NADMS).
- Non-Conformance with the Historic Preservation Act.
- Inadequate stormwater treatment.
- In addition to omitting the MD 200 Diversion Alternative from further study, MDOT SHA and FHWA have construed the purpose and need so narrowly as to exclude from consideration a number of reasonable alternatives.
- MDOT SHA and FHWA have failed to consider the Project's impacts from phasing.
- Lack of financial viability and incomplete project costs.

Next steps in the schedule:

Before the end of 2020: SHA begins the NEPA process for the northern part of I-270 to bring the projects together.

May 2021: SHA plans to publish their Final EIS and Record of Decision in selecting the Private Partner for Phase 1. Mandatory Referral Review.

ACTION: Motion of Vice Chair Hewlett to adopt the positions outlined above
Seconded by Commissioner Geraldo
7 approved the motion (Verma absent for vote)

ITEM 6

OFFICERS' REPORTS

Executive Director's Report

a) Employee Evaluations Not Completed by Due Date (September 2020) (For information only)

Secretary Treasurer Report

b) Investment Report FY19 4th Quarter report (For information only)

General Counsel Report

c) Litigation Report (For information only)

There being no further business to discuss, the meeting ended at 12:11 p.m.



James F. Adams, Senior Technical Writer



Asuntha Chiang-Smith, Executive Director

This page intentionally left blank.



Special Meeting of the Commission
Open Session Minutes
October 22, 2020

The Maryland-National Capital Park and Planning Commission met via videoconference with the Chair initiating the meeting at the Wheaton Headquarters Auditorium in Wheaton, Maryland. The meeting was broadcast by the Montgomery County Planning Department.

PRESENT

Montgomery County Commissioners

Casey Anderson, Chair
Gerald Cichy
Natali Fani-Gonzalez
Tina Patterson
Partap Verma

Prince George’s County Commissioners

Elizabeth M. Hewlett, Vice-Chair
Dorothy Bailey
William Doerner
Manuel Geraldo
A. Shuanise Washington

Chair Anderson called meeting to order at 10:02 a.m.

ITEM 1 COMMISSION SPECIAL MEETING AGENDA

ITEM 2 a. Health Insurance Rate Changes for Fiscal Year 2021

Executive Director Chiang-Smith shared a memo transmitted to Commissioners stating that the Municipal and County Government Employees Organization (MCGEO) agreed to the provisions stated within this morning for the final agreement. She thanked the negotiation team and Corporate Human Resources Director Spencer for his hard work last night coordinating communication between the negotiation team and the MCGEO leaders.

The Health Insurance Rate change as budgeted would have been a \$30/month increase for the costliest plan. During a fiscal year where Merit increases and COLAs were suspended for budgetary reasons, management felt the increase was an undue hardship on employees and their families. In order to mitigate the impact on employees and their families, the agency will reduce the increase to \$15 for the highest plan for calendar 2021. Funding would come out of the Group Insurance Fund. She noted the Fund currently has a balance of \$5.6M. This provision will cost \$2.8M and will reduce the cost for one year.

Vice Chair Hewlett praised the team for their hard work.

ACTION: Motion of Vice Chair Hewlett to approve the rate change
Seconded by Commissioner Washington
10 approved the motion

There being no further business to discuss, the meeting ended at 12:13 p.m.

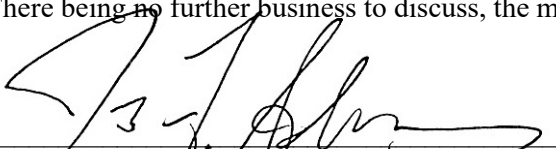
James F. Adams, Senior Technical Writer

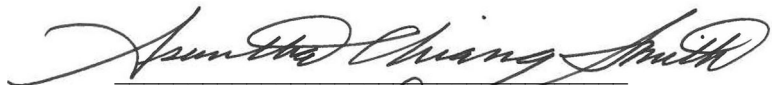
Asuntha Chiang-Smith, Executive Director

This page intentionally left blank.



**EXECUTIVE COMMITTEE MEETING MINUTES
November 4, 2020**

On November 4, 2020, the Maryland-National Capital Park and Planning Commission’s Executive Committee met via teleconference. Present were Chair Casey Anderson, Vice Chair Elizabeth M. Hewlett, and Executive Director Asuntha Chiang-Smith. Also present were:

Department Heads

- Steve Carter, Deputy Director, for Prince George’s County Parks and Recreation Director Bill Tyler (PGPR)
- Andree Checkley, Director, Prince George’s County Planning (PGPL)
- Adrian Gardner, General Counsel
- Mike Riley, Director, Montgomery County Parks (MCPK)
- Gwen Wright, Director, Montgomery County Planning (MCPL)
- Joe Zimmerman, Secretary-Treasurer

Presenters/Staff

- Anju Bennett, Corporate Policy and Management Operations Director
- Mazen Chilet, Chief Information Officer
- John Kroll, Corporate Budget Director
- William Spencer, Corporate Human Resource Director
- Wanda Wesley-Major, Risk and Safety Manager

Executive Director Chiang-Smith convened the meeting at 10:05 a.m.

ITEM 1a – APPROVAL OF EXECUTIVE COMMITTEE AGENDA

Discussion	No discussion
ACTION	Motion of Vice-Chair Hewlett, second by Chair Anderson. Agenda approved unanimously.

ITEM 1b – APPROVAL OF COMMISSION MEETING AGENDA for November 18, 2020

Discussion	No modification to the November Commission Meeting agenda:
ACTION/Follow-up	

ITEM 1c – ROLLING AGENDA FOR UPCOMING COMMISSION MEETINGS

Discussion	No modification
ACTION/Follow-up	

ITEM 2 – JANUARY 3, 2020 EXECUTIVE COMMITTEE MEETING MINUTES

Discussion	October 4, 2020 Open Session October 4, 2020 Closed Session
ACTION	Motion of Vice Chair Hewlett, second by Chair Anderson. Minutes approved unanimously.

Pursuant to Maryland General Provisions Article of the Annotated Code of Maryland, Section 3-305(b) (7) & (9), a closed session is proposed to consult with counsel for legal advice, conduct collective bargaining discussions and consider matters that relate to negotiation.

Vice-Chair Hewlett made a motion that the meeting move into Closed Session at 10:06 a.m. Chair Anderson seconded; motion approved unanimously. Open Session resumed at 10:16 a.m.

ITEM 4 – DISCUSSION/PRESENTATION ITEMS	
Discussion	<u>Item 4a. Ratification of Decision made for Item 3a (Bennett)</u>
ACTION	Vice Chair Hewlett motioned for ratification on decisions made during closed session; Chair Anderson seconded. Motion passed unanimously.
Discussion	<u>Item 4b. Investment Report August 2020 (information item only)</u>
ACTION	

There being no further business to discuss, the meeting adjourned at 10:17 a.m.

James F. Adams, Senior Technical Writer

Asuntha Chiang-Smith, Executive Director



EMPLOYEES' RETIREMENT SYSTEM
The Maryland-National Capital Park and Planning Commission

**BOARD OF TRUSTEES MEETING
MINUTES
Tuesday, September 1, 2020; 10:00 a.m.
via Microsoft Teams**

Due to COVID-19, the Maryland-National Capital Park and Planning Commission Employees' Retirement System Board of Trustees ("Board") met virtually through Microsoft Teams with CHAIRMAN HEWLETT leading the call from the County Administration Building in Upper Marlboro, Maryland on Tuesday, September 1, 2020. The meeting was called to order at 10:00 a.m. by CHAIRMAN HEWLETT.

Board Members Present

- Elizabeth M. Hewlett, Board of Trustees Chairman, Prince George's County Commissioner
- Gerald R. Cichy, Board of Trustees Vice Chairman, Montgomery County Commissioner
- Howard Brown, FOP Represented Trustee
- Asuntha Chiang-Smith, M-NCPPC Executive Director, Ex-Officio
- Pamela F. Gogol, Montgomery County Public Member
- Caroline McCarthy, Montgomery County Open Trustee
- Amy Millar, MCGEO Represented Trustee
- Sheila Morgan-Johnson, Prince George's County Public Member
- Elaine A. Stookey, Bi-County Open Trustee
- Joseph C. Zimmerman, CPA, M-NCPPC Secretary-Treasurer, Ex-Officio

Board Members Not Present

- Melissa D. Ford, Prince George's County Open Trustee

ERS Staff Present

- Andrea L. Rose, Administrator
- Heather D. Van Wagner, Senior Administrative Specialist
- Sheila S. Joynes, ERS Accounting Manager
- Annette Silvestri, Retirement Benefits Analyst

Presentations

- Groom Law Group – Alexander P. Ryan, Principal
- Wilshire Associates - Bradley A. Baker, Managing Director and Martell McDuffy, Senior Analyst
- M-NCPPC Legal Department – William C. Dickerson, Principal Counsel

ITEM 1 APPROVAL OF THE SEPTEMBER 1, 2020 CONSENT AGENDA

ACTION: MS. CHIANG-SMITH made a motion, seconded by MS. GOGOL to approve the Consent Agenda. The motion PASSED (9-0-1). MS. MCCARTHY abstained since she did not attend the July 7, 2020 Board meeting. (Motion #20-54)

ITEM 2 CHAIRMAN'S ITEMS

No items reported.

ITEM 3 MISCELLANEOUS

No items reported.

ITEM 4 REPORT OF THE ADMINISTRATOR

Andrea Rose presented the Administrator's Report dated August 25, 2020.

Ms. Rose introduced, Annette Silvestri, who joined the ERS team on August 17, 2020 as the new Retirement Benefits Analyst. Ms. Silvestri comes to the ERS with experience from Bank of New York Mellon (4+ years) and T. Rowe Price (15+ years). Ms. Silvestri has a bachelor's degree in Social Work and Psychology from UMBC. Given her background and experience, the ERS believes she will be a tremendous asset in transitioning to the new pension software system and in assisting members transitioning into retirement.

ITEM 5 MANAGER PRESENTATIONS**Wilshire Associates**

Presentations by Bradley A. Baker, Managing Director and Martell McDuffy, Senior Analyst

Wilshire Associates provided a Quarterly Investment Summary for the quarter ending June 30, 2020 and Mr. Baker provided a capital market review and reported on the fund's performance. The ERS' total fund return was 7.7% (net of fees) for the quarter, underperforming the target policy index return of 11.1%. For the YTD, three, five, and ten-years ended June 30, 2020 the ERS fund return was -3.20%, 5.8%, 6.3%, and 8.4%, respectively, compared to the target policy return of -3.30%, 5.4%, 5.60%, and 7.7%, respectively. The total market value through June 30, 2020 was \$944.3 million.

Mr. Baker said while 1Q2020 and 2Q2020 were vastly different in terms of performance, the ERS' portfolio held up well. The ERS was in the top 50% of peers for the 3-years ended June 30, 2020 and top 25% of peers for the 5-years ended June 30, 2020 which reflects the strength of the portfolio.

Grosvenor announced in an August 3, 2020 press release that it will become a publicly listed company. Management will continue to own in excess of 70% of the equity of the firm. There will be no change in the team, investment or operations committees or how Grosvenor does business. Wilshire does not anticipate any team or firm impacts but will obviously keep a close watch.

ITEM 6 CLOSED SESSION

At 11:10 p.m. CHAIRMAN HEWLETT requested a motion to go into Closed Session under General Provisions Article of the Annotated Code of Maryland Section 3-305(b)(5) to consider the investment of public funds; (8) to consult with staff, consultants, or other individuals about pending or potential litigation; (13) to comply with a specific constitutional, statutory, or judicially imposed requirement that prevents public disclosure about a particular proceeding or matter, namely the Maryland Public Information Act General Provisions 4-335 which prevents public disclosure of confidential commercial or financial information and Section 3-305(b)(7) to consult with counsel to obtain legal advice.

ACTION: VICE CHARIMAN CICHY made a motion, seconded by MS. CHIANG-SMITH to go into Closed Session. The motion PASSED unanimously (10-0). (Motion #20-55)

During Closed Session, the following action was taken:

1. The Board approved a Side Letter between the ERS and HarbourVest governing the ERS's investment in HarbourVest Credit Opportunities Fund II L.P
2. The Board approved MS. GOGOL to sit on the HarbourVest Credit Opportunities Fund II L.P. Advisory Committee.

The Board moved back into Open Session at 12:08 p.m.

ACTION: MS. CHIANG-SMITH made a motion, seconded by MS. MILLAR to ratify the actions taken in Closed Session. The motion PASSED unanimously (10-0). (Motion #20-59)

ACTION: VICE CHAIRMAN CICHY made a motion, seconded by MS. GOGOL to adjourn the Board meeting of September 1, 2020. The motion PASSED unanimously (10-0). (Motion #20-60)

The Board meeting of September 1, 2020 adjourned at 12:19 p.m.

Respectfully,

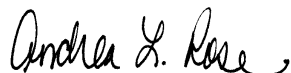

Andrea L. Rose
Administrator

This page intentionally left blank.

MEMORANDUM



EMPLOYEES' RETIREMENT SYSTEM
The Maryland-National Capital Park and Planning Commission
6611 Kenilworth Avenue, Suite 100
Riverdale, Maryland 20737

(301) 454-1415 - Telephone
(301) 454-1413 - Facsimile
<http://ers.mncppc.org>

Andrea L. Rose
Administrator

TO: The Commission

DATE: November 3, 2020

VIA: Elizabeth M. Hewlett *emd*
Chairman, Board of Trustees

FROM: Andrea L. Rose *Andrea L. Rose*
ERS Administrator

Subject: **Resolution #20-27 - Recommendation to Approve an Employer Contribution in the Amount of \$26,174,744 for Fiscal Year 2022**

RECOMMENDATION

At its November 3, 2020 meeting, the Employees' Retirement System (ERS) Board of Trustees ("Board") accepted the July 1, 2020 Actuarial Valuation presented by Cheiron. As a result, the Board recommends the Commission approve Resolution #20-27 which adopts an employer contribution in the amount of \$26,174,744 (15.18% of covered payroll) for fiscal year 2022.

BACKGROUND

In accordance with the ERS' Plan Document, Section 2.3(g), the Board shall recommend to the Commission the contributions to be made by the Commission under the provisions of the ERS.

Each year the ERS has an independent actuarial valuation performed to determine the funding requirements for the ERS. The actuarial valuation is designed to measure the current and future cost of retiree benefits based on employee demographics, assets and liabilities, plan provisions, and actuarial assumptions and methods. The actuary recommends an employer contribution to ensure sufficient assets are available for future benefits.

A pension plan is well funded when it has enough money in reserve to meet all expected future obligations to participants. The ERS' funding objective is to meet long-term benefit promises through employee and employer contributions that remain approximately level as a percent of member payroll. The July 1, 2020 actuarial valuation indicated a funded ratio (based on the actuarial value of assets) of 91.18%, which is down from 92.75% in 2019.

The July 1, 2020 actuarial valuation includes a change in the investment return assumption from 6.85% to 6.80%, which is consistent with industry trends and was approved by the Board earlier this year.

To meet the ERS' funding objectives, the recommended employer contribution of \$26,174,744 (15.18% of covered payroll) is payable July 1, 2021 for fiscal year 2022. The recommended employer contribution increased from \$22,312,947 (13.93% of covered payroll) as of July 1, 2019. The increase in the employer contribution from 2019 to 2020 can be primarily attributed to: 1) a \$54.6 million loss on the actuarial value of assets; 2) experience that varied from assumptions; and 3) an increase in liabilities due to a change in the investment return assumption from 6.85% to 6.80%; and 4) an increase in liabilities due to a programming change.

Cheiron's, Janet H. Cranna, FSA, EA, MAAA, Principal Consulting Actuary and Patrick Nelson, FSA, EA, MAAA, Associate Actuary will present the attached presentation at the Commission's November 18, 2020 meeting.

Thank you in advance for your consideration.

Attachment

1. Pension Actuarial Valuation as of July 1, 2020

Maryland-National Capital Park
and Planning Commission
Employees' Retirement System



Classic Values, Innovative Advice

Pension Actuarial Valuation as of July 1, 2020

November 18, 2020

Presented by

Janet Cranna, FSA, EA, MAAA

Patrick Nelson, FSA, EA, MAAA

Agenda

- Historical Review and Material Risks
- July 1, 2020 Actuarial Valuation Results
- Projections

20



The Actuarial Valuation Process



1. Collect information
 - Member data
 - Plan provisions
 - Asset informations
2. Apply assumptions
 - Demographic
 - Economic
3. Project all future benefit payments
4. Determine a present value of the benefits
5. Compare to assets
6. Calculate employer and employee contributions

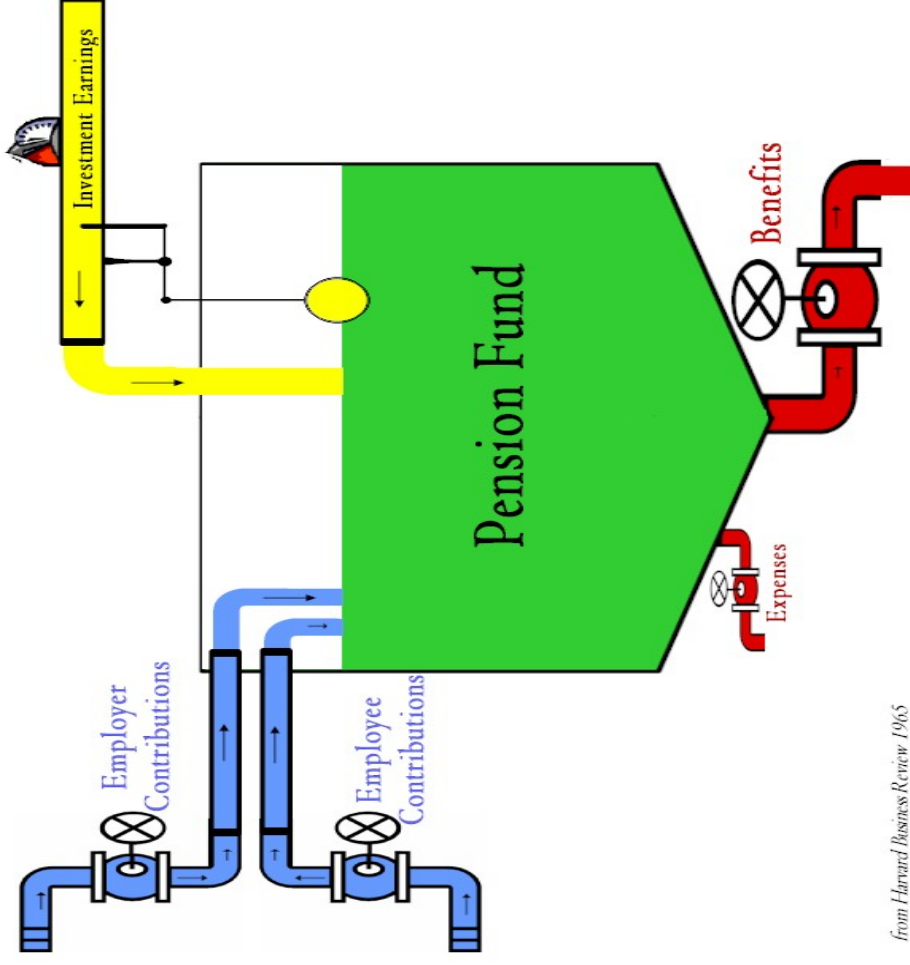

From Harvard Business Review 1965

Material Risks to the System



- Material risks identified:
 - **Investment Risk** – the potential for investment returns to be different than expected
 - **Longevity and other Demographic Risk** – the potential for mortality and other demographic experience to be different than expected
 - **Contribution Risk** – the potential that actual contributions will not adequately fund the Plan
 - **Plan Change Risk** – the potential for provisions of the plan to change and impact measurements
 - **Assumption Change Risk** – the potential for the environment to change such that future valuation assumptions are different than the current assumptions

Membership Trends



Historical Membership Counts

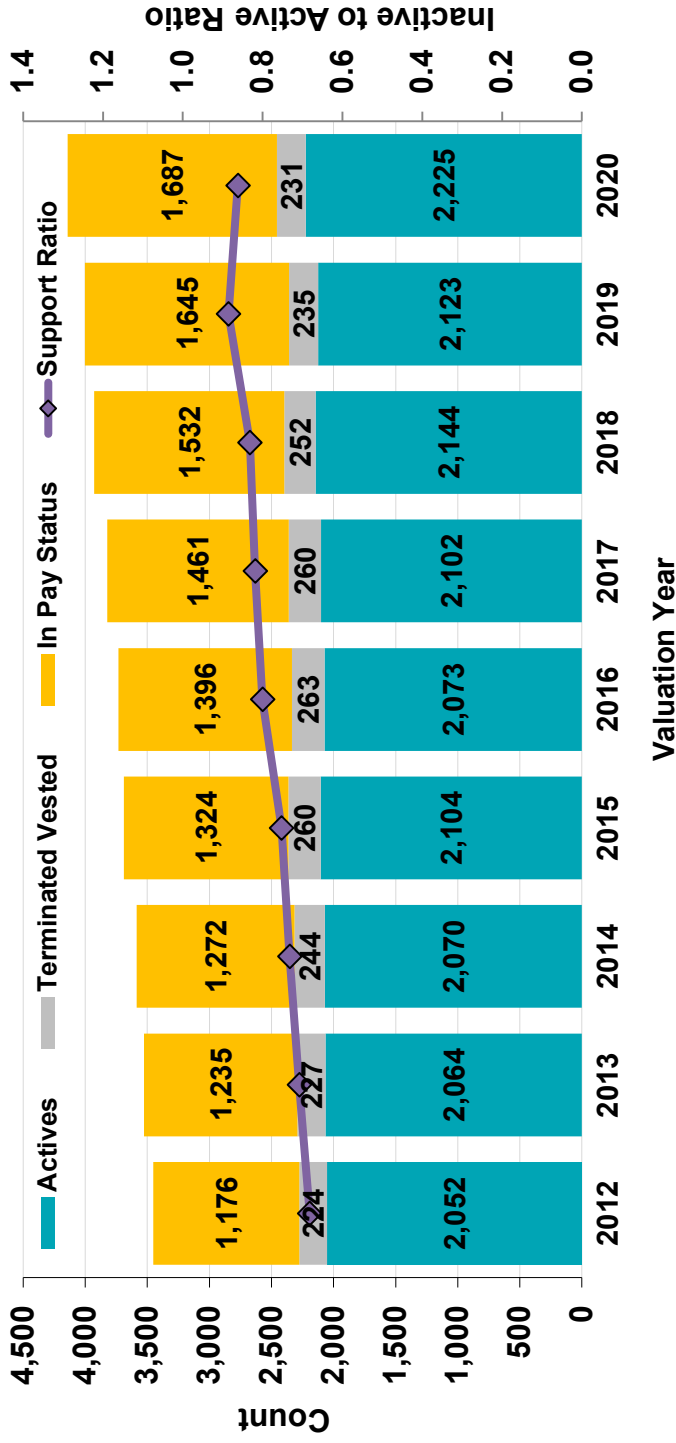

Support ratio above bars is the ratio of the number of inactive (Retirees and Deferred Vested) per active.

Support Ratio



Support Ratio

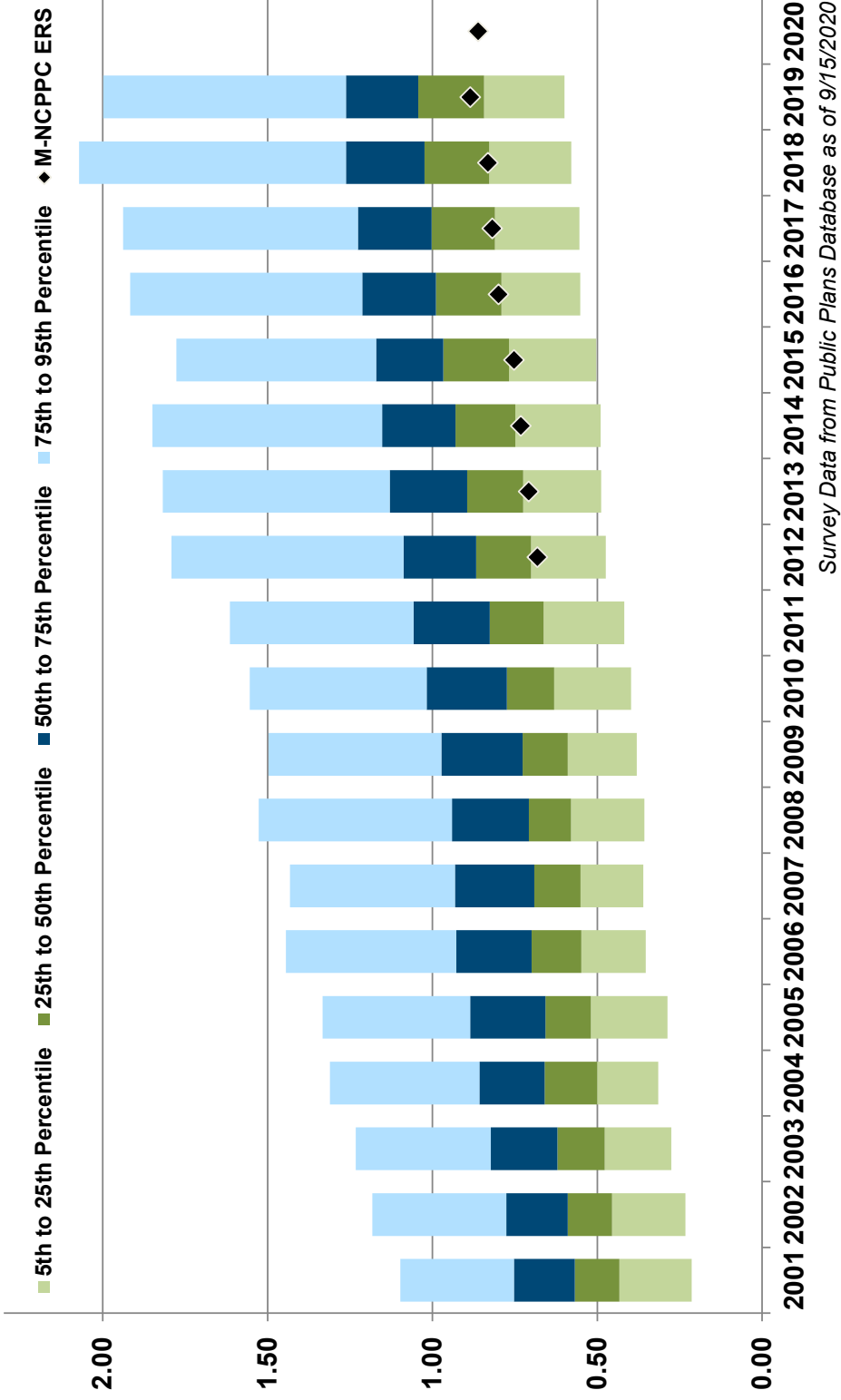

Assets and Liabilities



Pension Plan - Assets and Liabilities

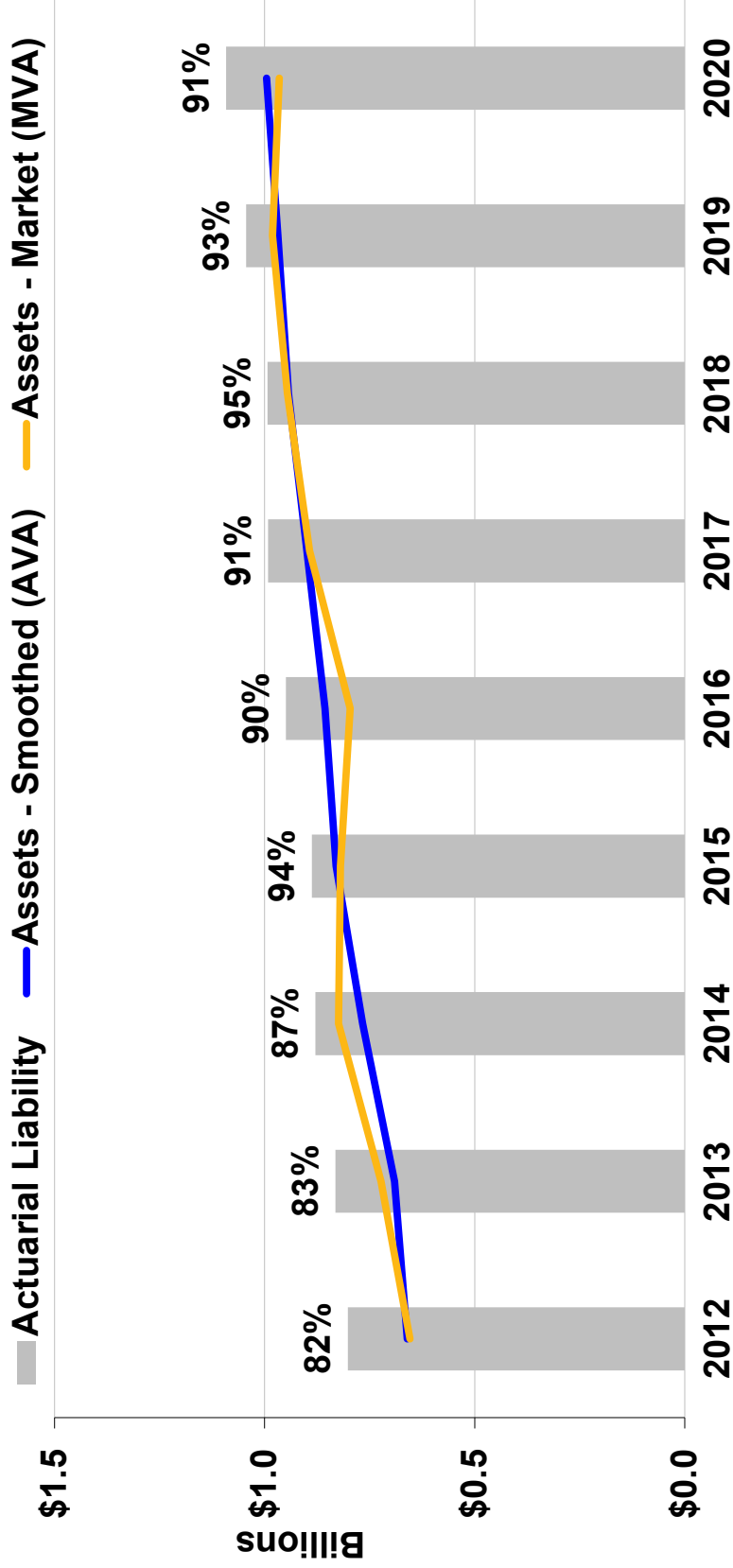

Funded status shown above bars is Actuarial Value of Assets divided by Actuarial Liability.

Discount Rate

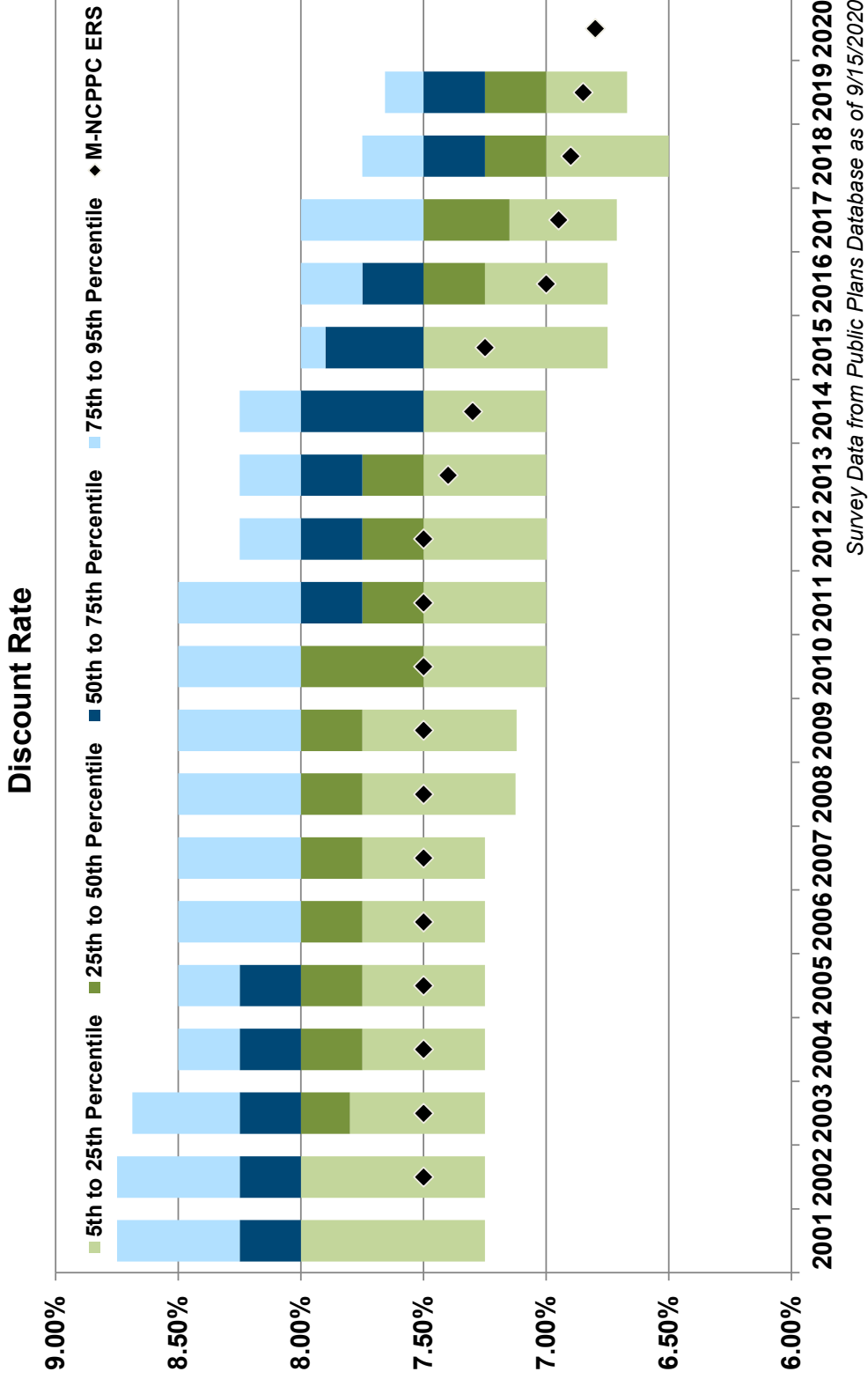

MVA Funded Ratio



MVA Funded Ratio

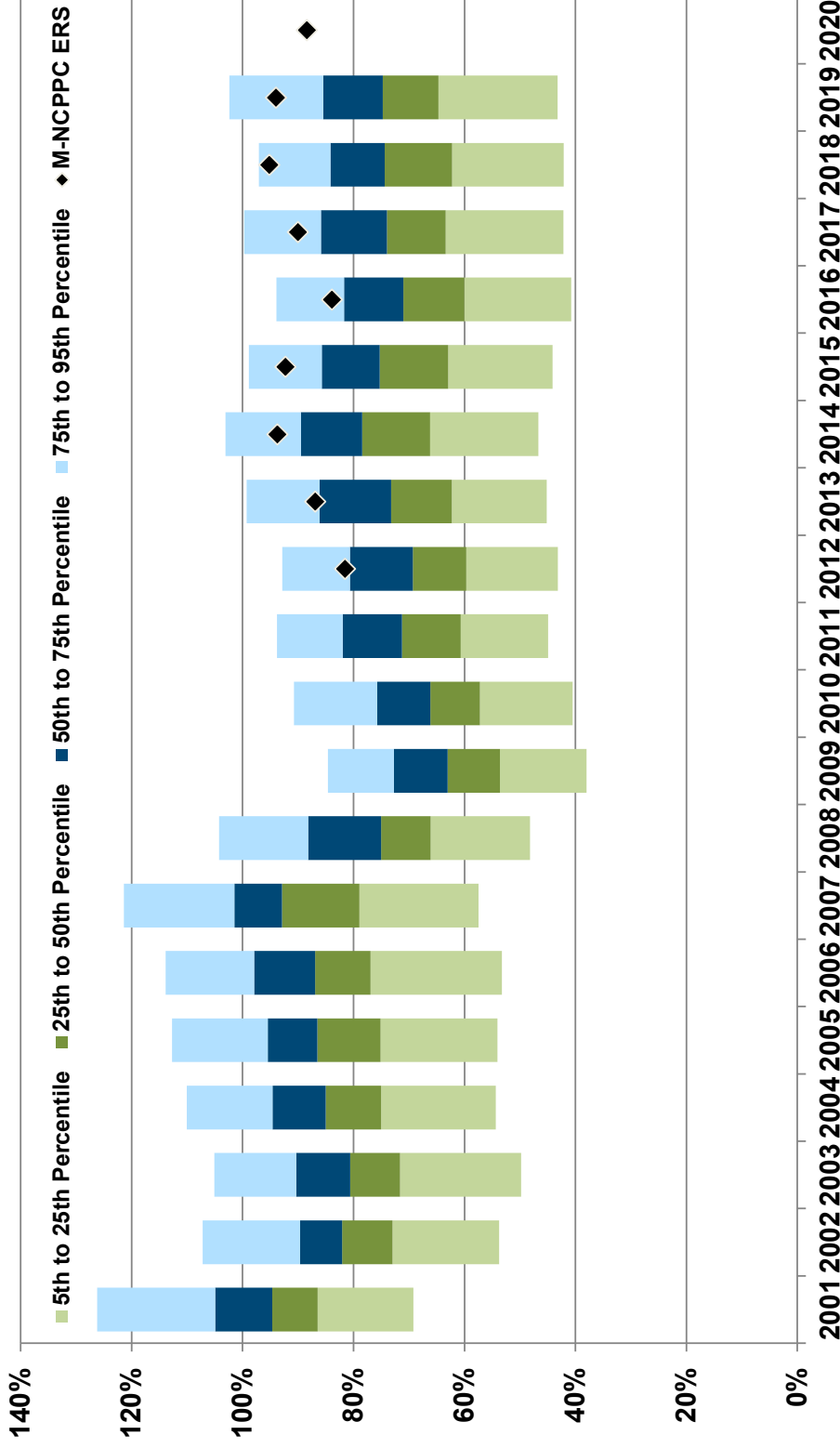

Survey Data from Public Plans Database as of 9/15/2020

Member Counts



Member Status	As of July 1, 2019	As of July 1, 2020	% Change
Active	2,123	2,225	4.80%
Terminated Vested	235	231	-1.70%
Terminated Non-Vested ¹	426	449	5.40%
Retired, Beneficiaries, and Disabled	<u>1,645</u>	<u>1,687</u>	2.55%
Total	4,429	4,592	3.68%

¹ Members still due a refund of employee contributions

Assets and Liabilities Comparison



- Market Value of Assets returned 1.14% and the Actuarial Value of Assets (AVA) returned 5.74% from July 1, 2019 to June 30, 2020, both below the assumed rate of 6.85%
 - Actuarial loss on investments was \$10.5 million.
- Actuarial liability loss of \$2.9 million
- Change in the discount rate from 6.85% to 6.80% increased liabilities by \$6.2 million
- Programming update which increased liabilities by \$4.8 million

29

Assets and Liabilities	As of July 1, 2019	As of July 1, 2020	% Change
Actuarial Liability (AL)	\$ 1,043,820,211	\$ 1,091,238,867	4.54%
Actuarial Value of Assets (AVA)	\$ 968,142,434	\$ 995,043,914	2.78%
Unfunded Actuarial Liability (UAL)	\$ 75,677,777	\$ 96,194,953	27.11%
Funded Ratio (AVA / AL)	92.75%	91.18%	-1.57%
Market Value of Assets (MVA)	\$ 981,261,569	\$ 964,901,537	-1.67%
Funded Ratio (MVA / AL)	94.01%	88.42%	-5.58%

Change in Liabilities



Source	(Gain) / Loss
Liabilities as of July 1, 2019	\$ 1,043,820,211
Change due to:	
Programming Update	4,751,809
Assumption Changes	6,170,260
Actuarial (Gain) / Loss	2,903,181
Benefits Accumulated and Other Sources	<u>33,593,406</u>
Total Liability Increase / (Decrease)	<u>47,418,656</u>
Liabilities as of July 1, 2020	\$ 1,091,238,867

30

Source	(Gain) / Loss	% of Liability
New members entering System	\$ 560,518	0.1%
Salary increases greater than expected	1,838,588	0.2%
Active member decrements	4,230,467	0.4%
Inactive mortality	(1,458,219)	-0.1%
COLA less than expected	(2,018,227)	-0.2%
Benefit payments less than expected	466,776	0.0%
Miscellaneous changes	<u>(716,722)</u>	<u>-0.1%</u>
Total Actuarial Liability (Gain) / Loss	\$ 2,903,181	0.3%

Membership and Liability By Plan



Number of Members by Plan

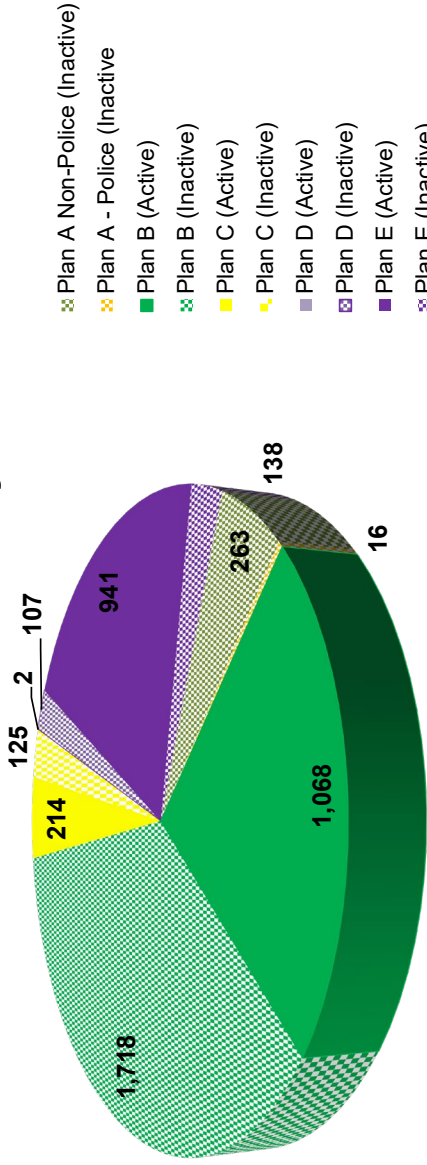

Actuarial Liability by Plan

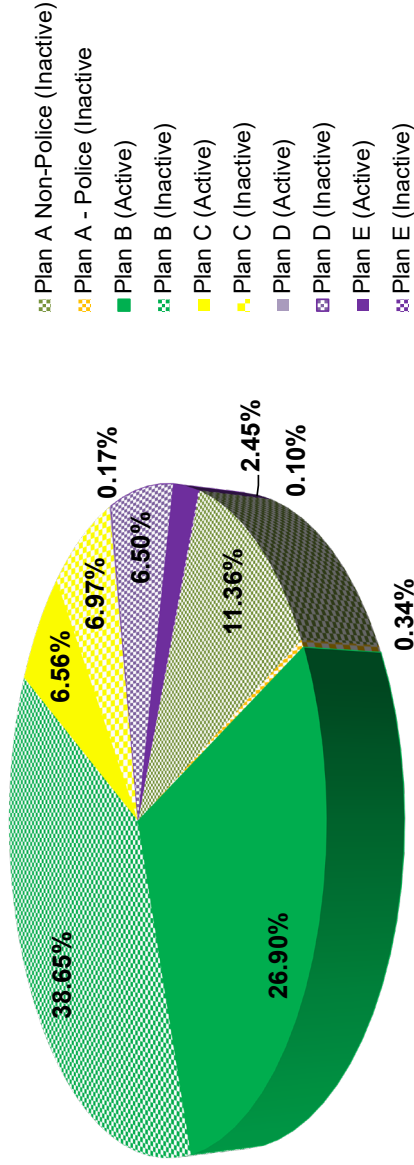

Employer Contribution by Plan



	Non-Police		Police		Plan B	Plan C	Plan D	Plan E	Total
	Plan A	Plan A	Plan A	Plan A					
Active Member Payroll	\$ 0	\$ 0	\$ 89,778,016	\$ 18,242,459	\$ 214,165	\$ 64,152,428	\$ 172,387,068		
Normal Costs									
Gross Normal Cost	\$ 0	\$ 0	\$ 9,516,952	\$ 3,644,347	\$ 35,179	\$ 7,112,226	\$ 20,308,704		
Estimated Expenses	248,030	7,443	1,430,516	295,210	145,717	55,562	2,182,478		
Reduction due to Expected Employee Contributions	<u>0</u>	<u>0</u>	<u>3,534,044</u>	<u>1,616,148</u>	<u>17,133</u>	<u>2,580,333</u>	<u>7,747,658</u>		
Net Employer Normal Cost	\$ 248,030	\$ 7,443	\$ 7,413,424	\$ 2,323,409	\$ 163,763	\$ 4,587,455	\$ 14,743,524		
--As a % of Payroll	0.00%	0.00%	8.26%	12.74%	76.47%	7.15%	8.55%		
Amortization Payment	\$ 0	\$ 0	\$ 7,279,994	\$ 1,774,652	\$ 47,222	\$ 662,796	\$ 9,764,664		
--As a % of Payroll	0.00%	0.00%	8.11%	9.73%	22.05%	1.03%	5.66%		
Actuarially Determined Employer Contribution payable at Beginning of Year	\$ 248,030	\$ 7,443	\$ 14,693,418	\$ 4,098,061	\$ 210,985	\$ 5,250,251	\$ 24,508,188		
--As a % of Payroll	0.00%	0.00%	16.37%	22.46%	98.52%	8.18%	14.22%		
Actuarially Determined Employer Contribution payable at End of Year	\$ 264,896	\$ 7,949	\$ 15,692,570	\$ 4,376,729	\$ 225,332	\$ 5,607,268	\$ 26,174,744		
--As a % of Payroll	0.00%	0.00%	17.48%	23.99%	105.21%	8.74%	15.18%		

Contribution Allocation



	Contribution for		Contribution
	FYE June 30, 2022	2020 Payroll	as % of Payroll
Non-Police	\$ 21,564,734	\$ 153,930,444	14.01%
Park Police	<u>4,610,010</u>	<u>18,456,624</u>	24.98%
Total	\$ 26,174,744	\$ 172,387,068	15.18%

Projections – Baseline



Stress Testing

P-scan

Amort Type	Rolling
Amort Period	15
Salary Increase	0.0%

Baseline	<input type="radio"/>
Historical	<input type="radio"/>
1937	<input checked="" type="radio"/>

PYE	2021	2022	2023	2024	2025	2026	2027	2028	2029	2030	2031	2032	2033	2034	2035	2036	2037	2038	2039	2040	Avg
	6.80%	6.80%	6.80%	6.80%	6.80%	6.80%	6.80%	6.80%	6.80%	6.80%	6.80%	6.80%	6.80%	6.80%	6.80%	6.80%	6.80%	6.80%	6.80%	6.80%	6.80%

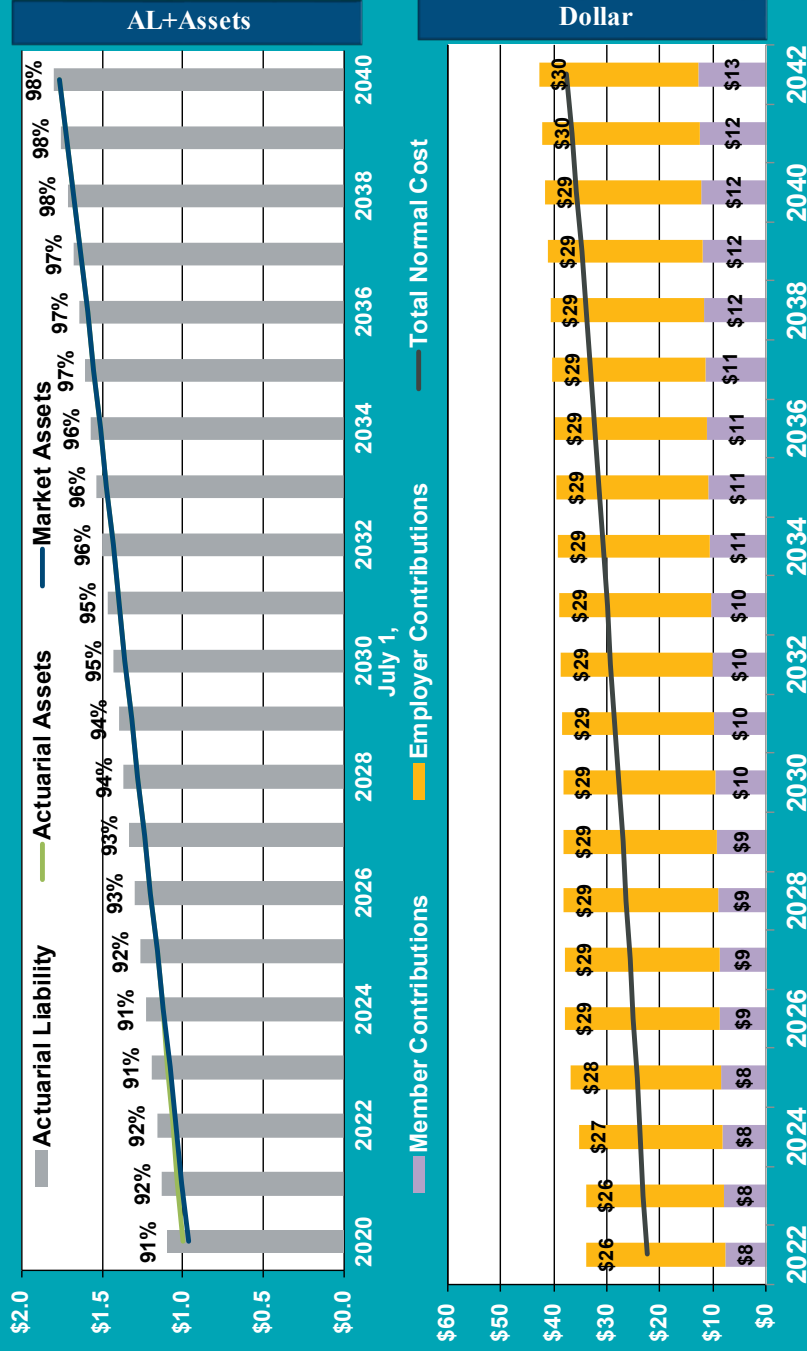

Projected Cash Flows



10-Year Projection of Employer Costs (dollars in millions)

Fiscal Year Ending June 30,	Normal Cost	Amortization of UAL	Estimated Expenses	Interest to End of Year	Total Employer Contribution	Prior Year Payroll	Employer Contribution as % of Payroll
2022	\$ 12.56	\$ 9.76	\$ 2.18	\$ 1.67	\$ 26.17	\$ 172.39	15.18%
2023	12.85	9.24	2.25	1.66	26.00	176.70	14.71%
2024	13.20	9.88	2.32	1.73	27.13	181.11	14.98%
2025	13.57	10.58	2.39	1.80	28.34	185.64	15.27%
2026	13.94	11.14	2.46	1.87	29.41	190.28	15.46%
2027	14.32	10.49	2.53	1.86	29.19	195.04	14.97%
2028	14.71	9.86	2.59	1.85	29.01	199.92	14.51%
2029	15.10	9.26	2.66	1.84	28.87	204.91	14.09%
2030	15.51	8.69	2.73	1.83	28.76	210.04	13.69%
2031	15.92	8.14	2.79	1.83	28.68	215.29	13.32%
2032	16.34	7.61	2.86	1.82	28.64	220.67	12.98%

Assumptions

- Future investment returns of 6.80%
- Total payroll increases 2.50%
- No liability gains or losses

Required Disclosures



The purpose of this presentation is to present the actuarial valuation results for the Maryland-National Capital Park and Planning Commission Employees' Retirement System (System). This presentation is for the use of the Board, System staff, and the Commission.

In preparing our presentation, we relied on information, some oral and some written, supplied by the System. This information includes, but is not limited to, the plan provisions, employee data, and financial information. We performed an informal examination of the obvious characteristics of the data for reasonableness and consistency in accordance with Actuarial Standard of Practice No. 23.

The actuarial assumptions and methods are outlined in the Actuarial Valuation Report as of July 1, 2020. The census data provided to us by the System was as of July 1, 2020.

36

The assumptions reflect our understanding of the likely future experience of the System, and the assumptions as a whole represent our best estimate for the future experience of the System. The results of this presentation are dependent upon future experience conforming to these assumptions. To the extent that future experience deviates from the actuarial assumptions, the true cost of the System could vary from our results.

This presentation and its contents have been prepared in accordance with generally recognized and accepted actuarial principles and our understanding of the Code of Professional Conduct and applicable Actuarial Standards of Practice set out by the Actuarial Standards Board as well as other applicable laws and regulations. Furthermore, as credentialed actuaries, we meet the Qualification Standards of the American Academy of Actuaries to render the opinion contained in this presentation. This presentation does not address any contractual or legal issues. We are not attorneys, and our firm does not provide any legal services or advice.

This presentation was prepared exclusively for the Maryland-National Capital Park and Planning Commission Employee's Retirement System for the purpose described herein. Other users of this presentation are not intended users as defined in the Actuarial Standards of Practice, and Cheiron assumes no duty or liability to any other user.



THE MARYLAND-NATIONAL CAPITAL PARK AND PLANNING COMMISSION

6611 Kenilworth Avenue • Riverdale, Maryland 20737

M-NCPPC RESOLUTION NO. 20-27

RECOMMENDATION TO APPROVE AN EMPLOYER RETIREMENT CONTRIBUTION IN THE AMOUNT OF \$26,174,744
FOR FISCAL YEAR 2022

WHEREAS, The Maryland-National Capital Park and Planning Commission (the “Commission”) as Plan Sponsor entered into a Pension Trust Agreement as of July 26, 1972 and amended on June 13, 1979 (“the Agreement”) with the Employees’ Retirement System of the Maryland-National Capital Park and Planning Commission (“ERS” or the “Plan”); and

WHEREAS, the “FIRST” section of the Agreement states that the Board of Trustees shall be responsible for the collection of contributions to the Plan; and

WHEREAS, Section 2.3(g) of the ERS Plan Document states that the Board of Trustees shall recommend to the Commission the contributions to be made by the Commission under the provisions of the Retirement System; and

WHEREAS, the Board of Trustees engaged Cheiron (“the Actuary”) to prepare an ERS Actuarial Valuation as of July 1, 2020; and

WHEREAS, the ERS Actuarial Valuation as of July 1, 2020 projected a Fiscal Year 2022 Plan Sponsor contribution in the amount of \$26,174,744.

NOW THEREFORE, BE IT RESOLVED, that the Commission as Plan Sponsor approves a \$26,174,744 payment to the ERS Trust Fund; and

BE IT FURTHER RESOLVED that the Maryland-National Capital Park and Planning Commission does hereby authorize the Executive Director and other officers to take action as may be necessary to implement this resolution.

APPROVED FOR LEGAL SUFFICIENCY:

William Dickerson,
M-NCPPC Legal Department,
November 4, 2020

This page intentionally left blank.

**THE MARYLAND-NATIONAL CAPITAL PARK AND PLANNING COMMISSION
EMPLOYEE PERFORMANCE EVALUATIONS NOT COMPLETED BY DUE DATE
BY DEPARTMENT AS OF OCTOBER 2020**

	<u>31 - 60 DAYS</u>		<u>61 - 90 DAYS</u>		<u>91 + DAYS</u>		<u>DEPARTMENT TOTALS</u>	
	Sep-20	Oct-20	Sep-20	Oct-20	Sep-20	Oct-20	Sep-20	Oct-20
CHAIRMAN, MONTGOMERY COUNTY	0	0	0	0	0	0	0	0
CHARIMAN, PRINCE GEORGE'S COUNTY	0	0	0	0	0	0	0	0
OFFICE OF CIO	1	2	5	3	3	4	9	9
OFFICE OF INSPECTOR GENERAL	0	0	0	0	0	0	0	0
EXECUTIVE COMMITTEE/CHAIRS	0	0	0	0	0	0	0	0
DEPT. OF HUMAN RESOURCES & MGT.	3	0	2	2	0	0	5	2
LEGAL DEPARTMENT	0	2	0	0	0	0	0	2
FINANCE DEPARTMENT	10	1	3	5	2	5	14	12
PRINCE GEORGE'S PLANNING	4	2	0	0	0	0	4	2
PRINCE GEORGE'S PARKS & RECREATION	29	29	3	4	1	0	33	33
MONTGOMERY COUNTY PARKS	18	26	2	4	1	0	21	30
MONTGOMERY COUNTY PLANNING	11	0	1	0	0	0	8	11
DEPARTMENT TOTAL BY DAYS LATE	76	62	16	18	7	9		
COMMISSION-WIDE TOTAL							94	101

**DEPARTMENTS HAVE BEEN NOTIFIED OF LATE EVALUATIONS.

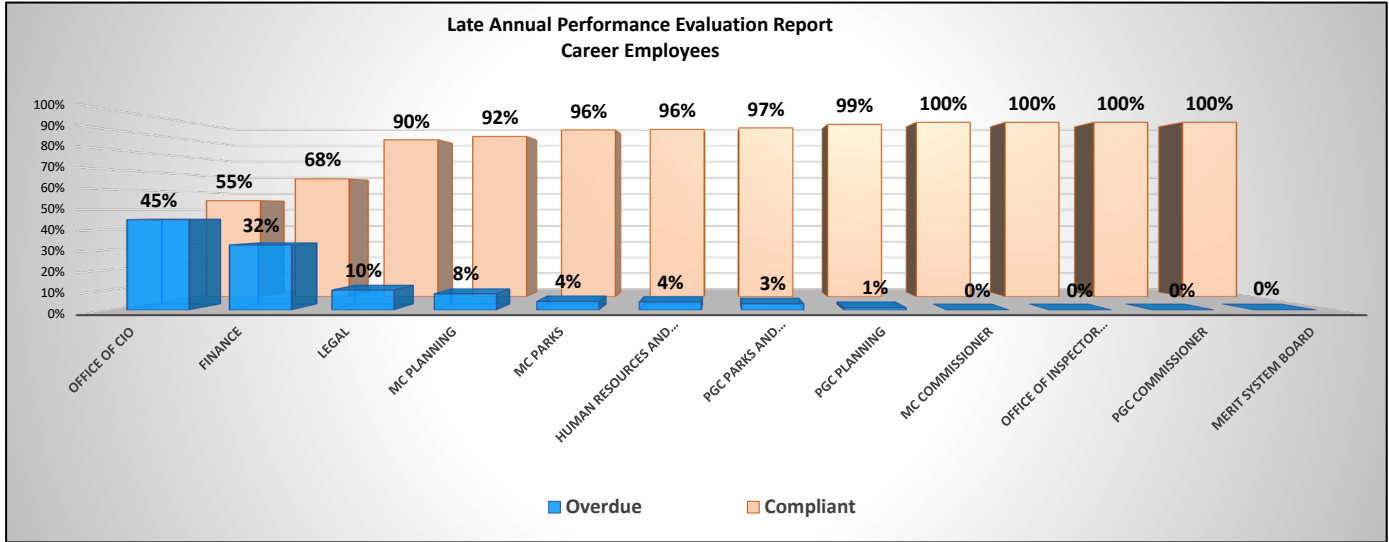

*Data As Of October 31, 2020

Employee Count	Evaluation Status		Total Employees
	Overdue	Compliant	
Department	Overdue	Compliant	Total Employees
Finance	12	25	37
Human Resources and Mgt	2	48	50
Legal	2	18	20
MC Commissioner		5	5
MC Parks	30	669	699
MC Planning	11	125	136
Merit System Board		1	1
Office of CIO	9	11	20
Office of Inspector General		4	4
PGC Commissioner		8	8
PGC Parks and Recreation	33	1,019	1,052
PGC Planning	2	170	172
Total Employees	101	2,103	2,204



THE MARYLAND-NATIONAL CAPITAL PARK AND PLANNING COMMISSION
 TREASURY OPERATIONS, FINANCE DEPARTMENT
 6611 Kenilworth Avenue, Suite 302, Riverdale, MD 20737
 Telephone (301) 454-1592 / Fax (301) 454-1637

MEMO

TO: Commissioners
VIA: Joseph Zimmerman, Secretary-Treasurer
FROM: Tanya Hankton, Investment & Treasury Operations Manager *T.H.*
DATE: 10/12/2020
SUBJECT: Investment Report – September 2020

The Commission’s pooled cash investment portfolio totaled \$454.5 million as of September 30, 2020, with a 0.4% increase from August 31, 2020. Details are as follows:

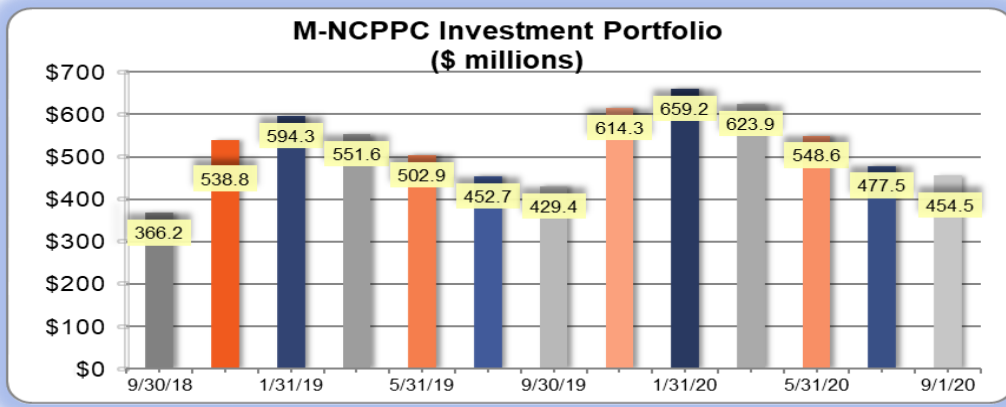

The composition of the pooled cash portfolio as of September 30, 2020 is summarized below:

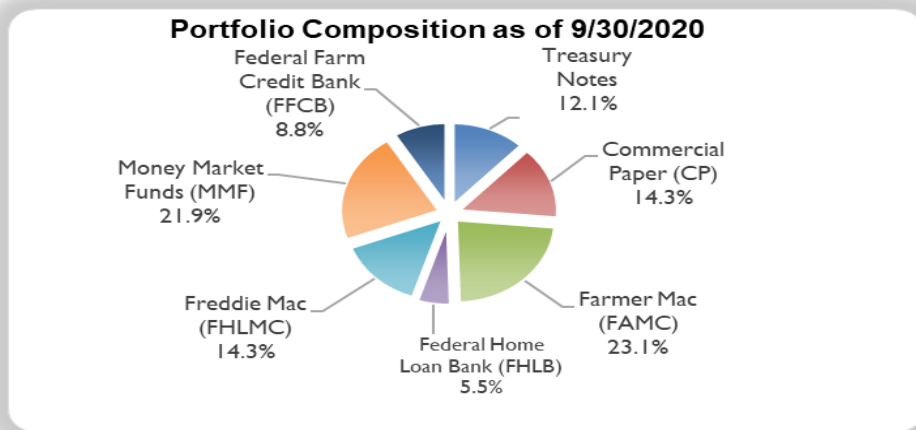

Current Investment Portfolio - September 2020

Instrument	Limit	Actual	Par Value	Return (B/E)
Farmer Mac	20%	23.1%	105,000,000	1.83%
Money Funds	* 25%	21.9%	\$ 99,556,052	0.24%
Commercial Paper	10%	14.3%	65,000,000	1.86%
Freddie Mac	20%	14.3%	65,000,000	0.32%
Treasury Notes	100%	12.1%	55,000,000	0.57%
Federal Farm Credit Bank	20%	8.8%	40,000,000	0.67%
Federal Home Loan Banks	20%	5.5%	25,000,000	0.19%
Fannie Mae	20%	0.0%	-	0.00%
Certificates of Deposit	50%	0.0%	-	0.00%
Bankers Acceptances	50%	0.0%	-	0.00%
Repurchase Agreements	60%	0.0%	-	0.00%
		100%	\$ 454,556,052	1.07%

*As of 9/30/2020

The pooled cash portfolio complied with all policy limits with regards to product types and proportions throughout the month.

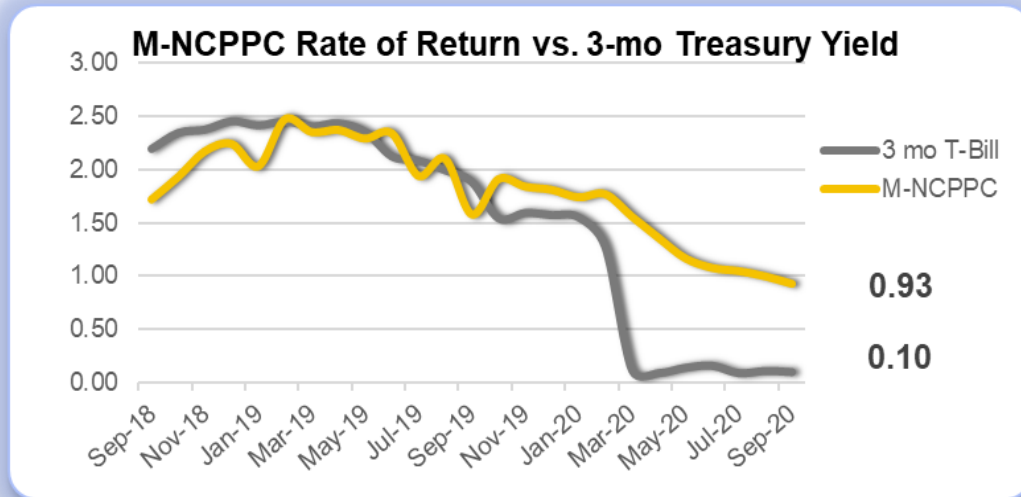

In addition to the product limits, portfolio purchases also adhered to the 30% limit per dealer. Dealer participation is shown below:

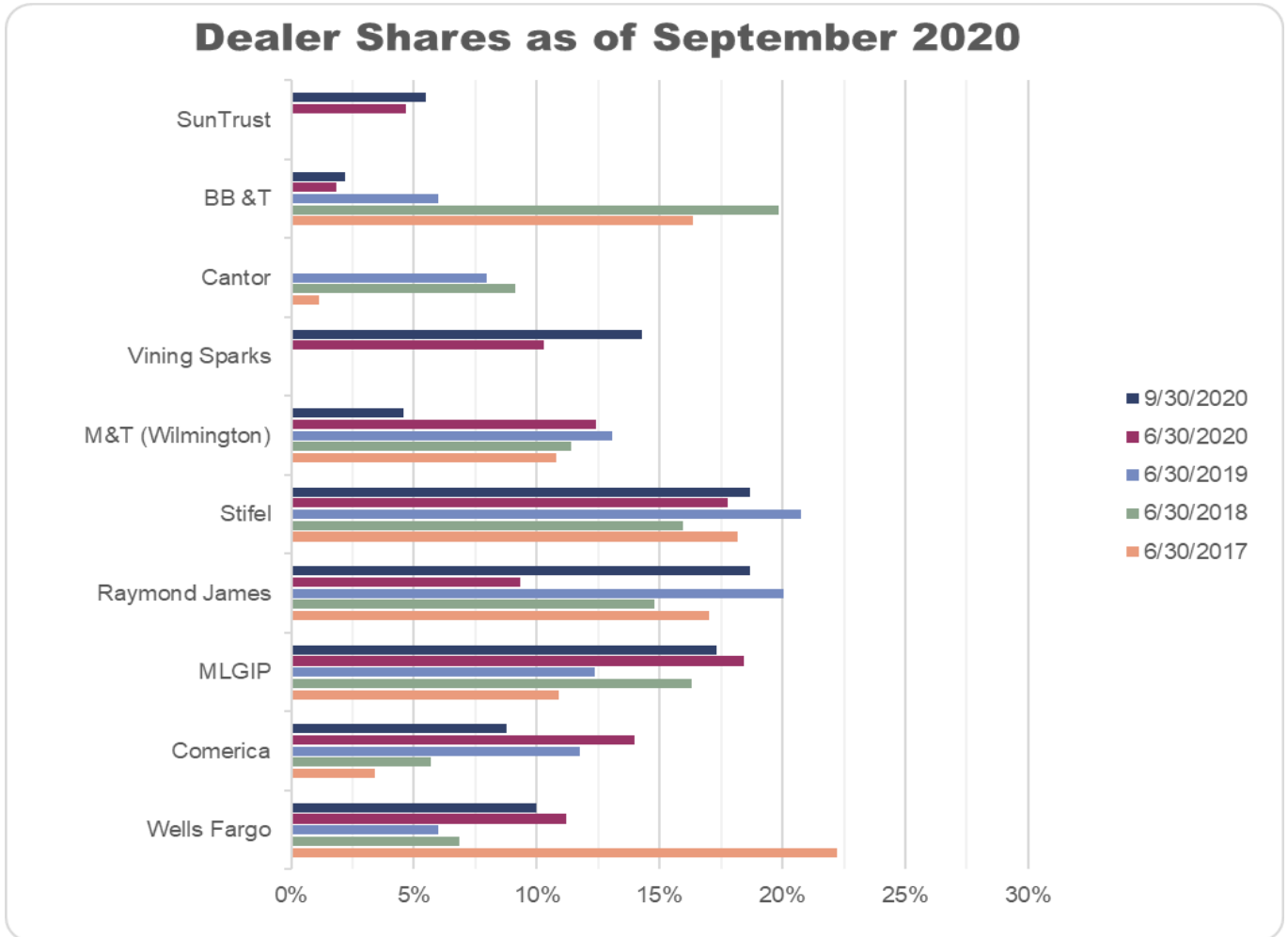

The market values of unspent debt balances (invested by T. Rowe Price) were as follows:

Market Value - September 2020	
Prince George's County (PGC-2018A)	\$ 11,586,240
Montgomery County (MC-2020A)	10,000,963
Montgomery County (MC-2018A)	2,426,418
	<u>\$ 24,013,621</u>

The Commission had no debt service payments during the month.

Details by issue of debt outstanding as of September 30, 2020 appear below:

Debt Balances - September 2020					
	Initial Par	Amount Outstanding	% Outstanding	Issue Date	Maturity Date
Bi-County					
Total Bi-County	\$ -	\$ -	0%		
Prince George's County					
NN-2 (<i>Refunded Z-2</i>)	14,080,000	1,335,000	9%	Mar-10	May-21
PGC-2012A (<i>Refunded P-2, M-2, EE-2</i>)	11,420,000	3,465,000	30%	Jun-12	Jan-24
PGC-2014A	26,565,000	20,340,000	77%	May-14	Jan-34
PGC-2015A (<i>Refunded JJ-2</i>)*	24,820,000	20,660,000	83%	Oct-15	Jan-36
PGC-2017A	33,000,000	28,050,000	85%	Jul-17	Jan-37
PGC-2018A	31,000,000	29,450,000	95%	Nov-19	Nov-38
Total Prince George's County	\$ 140,885,000	\$ 103,300,000	73%		
Montgomery County					
LL-2	8,405,000	400,000	5%	May-09	Nov-20
MC-2012A (<i>Refunded CC-2, FF-2</i>)	12,505,000	7,335,000	59%	Apr-12	Dec-32
MC-2012B	3,000,000	2,115,000	71%	Apr-12	Dec-32
MC-2014A	14,000,000	10,850,000	78%	Jun-14	Jun-34
MC-2016A	12,000,000	10,200,000	85%	Apr-16	Nov-35
MC-2016B (<i>Refunded FF-2, II-2, MM-2</i>)	6,120,000	5,355,000	88%	Apr-16	Nov-28
MC-2016C (<i>Refunded FF-2 ALA of 2004</i>)	1,075,000	620,000	58%	Apr-16	Nov-24
MC-2017A	8,000,000	6,800,000	85%	Apr-17	Nov-36
MC-2018A	12,000,000	11,400,000	95%	Oct-18	Nov-38
MC-2018B	3,000,000	2,400,000	80%	Oct-18	Nov-23
MC-2020A	10,000,000	10,000,000	100%	Jun-20	Nov-40
Total Montgomery County	\$ 90,105,000	\$ 67,475,000	75%		
Total	\$ 230,990,000	\$ 170,775,000	74%		

ATTACHMENT A

THE MARYLAND-NATIONAL CAPITAL PARK AND PLANNING COMMISSION

REPORT ON COMPLIANCE TO INVESTMENT POLICY Approved March 21, 2012

FISCAL YEAR 2021 – September 30, 2020

OBJECTIVES	Met Objective	Within Limits	Comments
Protection of principal	Yes		
Limiting types and amounts of securities	Limit	Yes	
US Government	100%		All securities purchases were within the limits established by the Investment Policy at the time of purchase of the investments. This monthly report is prepared for the Secretary-Treasurer to demonstrate compliance with investment policy objectives and limitations.
US Federal Agencies - combined	60%		
US Federal Agencies - each	20%		
Repurchase Agreements	60%		
CD's and Time Deposits	50%		
Commercial Paper	10%		
Money Market Mutual Funds	25%		
MD Local Gov't Investment Pool	25%		
Investing Bond Proceeds:			
State and local agency securities	100%		
Money Market Mutual Funds	10%		
Bond Proceeds:		Yes	T. Rowe Price managed all funds within limits
Highly-rated state / local agency securities			
Highly-rated money market mutual funds (Max. 10% in lower-rated funds)			
Pre-qualify financial institutions, broker/dealers, intermediaries and advisers		Yes	All firms must meet defined capital levels and be approved by the Secretary-Treasurer
Ensure competition among participants	30%	Yes	No dealer shares exceeded 30%
Competitive Bidding		Yes	All purchases awarded competitively.
Diversification of Maturities		Yes	All maturities within limits
Majority of investments shall be a maximum maturity of one (1) year. A portion may be as long as two years.			
Require third-party collateral and safekeeping, and delivery-versus-payment settlement		Yes	M&T Investments serves as custodian, monitoring compliance daily
Maintain sufficient liquidity		Yes	Sufficient funds available for all cash requirements during period
Attain a market rate of return		Yes	More than market by 83 basis points.
The pro-rated rates of return for T-bills and the portfolio were 0.10% and 0.93% , respectively.			

This page intentionally left blank.



Office of the General Counsel
Maryland-National Capital Park and Planning Commission

Reply To

November 2, 2020

Adrian R. Gardner
General Counsel
6611 Kenilworth Avenue, Suite 200
Riverdale, Maryland 20737
(301) 454-1670 • (301) 454-1674 fax

MEMORANDUM

TO: The Maryland-National Capital Park and Planning Commission

FROM: Adrian R. Gardner
 General Counsel

RE: Litigation Report for October 2020 – FY 2021

Please find the attached litigation report we have prepared for your meeting scheduled on Wednesday, November 18, 2020. As always, please do not hesitate to call me in advance if you would like me to provide a substantive briefing on any of the cases reported.

Table of Contents – October – FY 2021 Report

Composition of Pending Litigation.....	Page 01
Overview of Pending Litigation (Chart).....	Page 01
Litigation Activity Summary	Page 02
Index of New YTD Cases (FY21)	Page 03
Index of Resolved YTD Cases (FY21)	Page 04
Disposition of FY21 Closed Cases Sorted by Department	Page 05
Index of Reported Cases Sorted by Jurisdiction.....	Page 06
Litigation Report Ordered by Court Jurisdiction.....	Page 08

This page intentionally left blank.

October 2020 Composition of Pending Litigation

(Sorted by Subject Matter and Forum)

	STATE TRIAL COURT	MARYLAND COSA	MARYLAND COURT OF APPEALS	FEDERAL TRIAL COURT	FEDERAL APPEALS COURT	U.S. SUPREME COURT	SUBJECT MATTER TOTALS
ADMIN APPEAL: LAND USE	9	4	1				14
ADMIN APPEAL: OTHER							
LAND USE DISPUTE							
TORT CLAIM	10						10
EMPLOYMENT DISPUTE	1			1			2
CONTRACT DISPUTE	4						4
PROPERTY DISPUTE							
CIVIL ENFORCEMENT							
WORKERS' COMPENSATION	5						5
DEBT COLLECTION							
BANKRUPTCY							
MISCELLANEOUS							
PER FORUM TOTALS	29	4	1	1			35

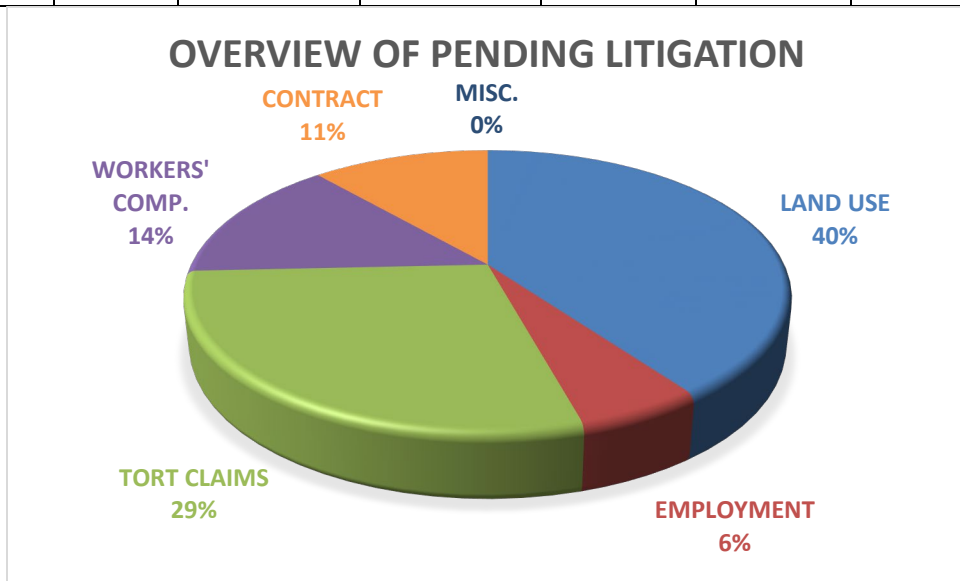

October 2020 Litigation Activity Summary

	COUNT FOR MONTH			COUNT FOR FISCAL YEAR 2021			
	Pending In Sept. 2020	New Cases	Resolved Cases	Pending Prior F/Y	New Cases F/YTD**	Resolved Cases F/YTD**	Pending Current Month
Admin Appeal: Land Use (AALU)	15		1	8	8	2	14
Admin Appeal: Other (AAO)							
Land Use Disputes (LD)							
Tort Claims (T)	9	1		5	5		10
Employment Disputes (ED)	3		1	3		1	2
Contract Disputes (CD)	3	1			4		4
Property Disputes (PD)							
Civil Enforcement (CE)							
Workers' Compensation (WC)	5			3	2		5
Debt Collection (D)							
Bankruptcy (B)							
Miscellaneous (M)							
Totals	35	2	2	19	19	3	35

**INDEX OF YTD NEW CASES
(7/1/2020 TO 6/30/21)**

A. <u>New Trial Court Cases.</u>	<u>Unit</u>	<u>Subject Matter</u>	<u>Month</u>
Getnet v. M-NCPPC	PG	Tort	July 20
HMF Paving Contractors, Inc. v. M-NCPPC	MC	Contract	July 20
Snyder v. State of Maryland, et al.	PG	Tort	July 20
Amica Mutual Insurance Company v. Montgomery County, Maryland, et al.	MC	Tort	Aug. 20
Uzlyan v. Montgomery County, Maryland, et al.	MC	Tort	Aug. 20
Heard v. M-NCPPC	PG	AALU	Aug. 20
Wolf, et al. v. Planning Board of Prince George's County	PG	AALU	Aug. 20
Structural Engineering Group Inc. v. M-NCPPC	MC	Contract	Aug. 20
Concerned Citizens of Cloverly, et al v. Montgomery County Planning Board	MC	AALU	Sep. 20
Shipkovitz v. Montgomery County Planning Board	MC	AALU	Sep. 20
Coakley & Williams v. Commission	PG	Contract	Sep. 20
Gibson v. Commission	PG	WC	Sep. 20
Murray v. Commission	PG	WC	Sep. 20
Newton, et al. v. Prince George's County Planning Board	PG	AALU	Sep. 20
Dana v. Lenk, et al.	MC	Tort	Oct 20
HMF Paving Contractors, Inc. v. M-NCPPC	MC	Contract	Oct 20

B. <u>New Appellate Court Cases.</u>	<u>Unit</u>	<u>Subject Matter</u>	<u>Month</u>
Benton v. Woodmore Overlook Commercial, LLC	PG	AALU	Aug. 20
Benton v. Woodmore Overlook Commercial, LLC	PG	AALU	Sep. 20
Estreicher v. Montgomery County Planning Board	MC	AALU	Sep. 20
Benton v. Woodmore Overlook Commercial LLC	PG	AALU	Sep. 20

**INDEX OF YTD RESOLVED CASES
(7/1/2020 TO 6/30/2021)**

<u>A. Trial Court Cases Resolved.</u>	<u>Unit</u>	<u>Subject Matter</u>	<u>Month</u>
McCourt v. Commission	PG	ED	Sep. 20
Estreicher v. Montgomery County Planning Board	MC	AALU	Sep. 20
<u>B. Appellate Court Cases Resolved.</u>	<u>Unit</u>	<u>Subject Matter</u>	<u>Month</u>
Benton v. Woodmore Overlook Commercial, LLC	PG	AALU	July 20

(Appeared on the June report in error. The Commission was not a party to this suit)

Disposition of FY21 Closed Cases Sorted by Department

CLIENT	PRINCIPAL CAUSE OF ACTION IN DISPUTE	DISPOSITION
Employees Retirement System		
Finance Department		
Department of Human Resources & Management		
McCourt v. Commission	Judicial Review of Merit Board Decision related to reclassification under the Administrative Series	09/04/20 – Decision of Merit Board Affirmed.
Montgomery County Department of Planning		
Montgomery County Department of Parks		
Montgomery County Park Police		
Montgomery County Planning Board		
Prince George's County Department of Parks and Recreation		
Prince George's County Planning Department		
Prince George's County Planning Board		
Prince George's Park Police		
Office of Internal Audit		

INDEX OF CASES

DISTRICT COURT FOR MONTGOMERY COUNTY, MARYLAND	8
DISTRICT COURT FOR PRINCE GEORGE’S COUNTY, MARYLAND	8
CIRCUIT COURT FOR ANNE ARUNDEL COUNTY, MARYLAND	8
Maryland-National Capital Park and Planning Commission v. Mail My Meds, LLC	8
CIRCUIT COURT FOR MONTGOMERY COUNTY, MARYLAND	9
Amica Mutual Insurance Company v. Montgomery County, Maryland, et al.	9
Concerned Citizens of Cloverly, et al. v. Montgomery County Planning Board.....	9
Dana v. Lenk, et al.	10
HMF Paving Contractors Inc. v. Maryland-National Park and Planning Commission	10
HMF Paving Contractors Inc. v. Maryland-National Park and Planning Commission	10
Jan A.J. Bove, et al. v. Montgomery County Planning Board	11
Kosary v. Montgomery County Planning Board	11
Shipkovitz v. Montgomery County Planning Board.....	12
Structural Engineering Group Inc. v. Maryland-National Capital Park and Planning Commission.....	12
Uzlyan v. Montgomery County, Maryland, et al.	13
CIRCUIT COURT FOR PRINCE GEORGE’S COUNTY, MARYLAND	14
6525 Belcrest Road, LLC v. Dewey, L.C., et al.....	14
Alexander v. Proctor.....	15
Brown v. City of Bowie	16
Coakley & Williams Construction v. Commission	16
Coe v. Commission	17
Commission v. Batson	17
Getnet v. Maryland-National Capital Park and Planning Commission	18
Gibson v. Commission	18
Heard v. Maryland-National Capital Park and Planning Commission.....	19
Jackson v. Prince George’s County Sports & Learning Complex.....	19
King v. Commission	20
Montague v. Newton White Mansion	20
Murray v. Commission	21
Newton, et al. v. Prince George’s County Planning Board	21
Pumphrey v. Wilson	22
Snyder v. State of Maryland, et al.	22
Stewart v. P.G. Planning Board	23
Wolf, et al. v. Planning Board of Prince George’s County	23

MARYLAND COURT OF SPECIAL APPEALS	24
Benton v. Woodmore Overlook Commercial, LLC	24
Benton v. Woodmore Overlook Commercial, LLC	25
Estreicher v. Montgomery County Planning Board	25
Gaspard v. Montgomery County Planning Board	26
MARYLAND COURT OF APPEALS.....	26
Benton v. Woodmore Overlook Commercial, LLC	26
U.S. DISTRICT COURT OF MARYLAND	27
Evans v. Commission, et al.....	27

DISTRICT COURT FOR MONTGOMERY COUNTY, MARYLAND

No Pending Cases

DISTRICT COURT FOR PRINCE GEORGE'S COUNTY, MARYLAND

No Pending Cases

CIRCUIT COURT FOR ANNE ARUNDEL COUNTY, MARYLAND

Maryland-National Capital Park and Planning Commission v. Mail My Meds, LLC

Case No. C-02-CV-20-001143 (WC)

Lead Counsel: Foster
Other Counsel:

Abstract: Judicial Review of WCC decision regarding mail order prescription medication.

Status: Awaiting hearing.

Docket:

05/01/2020	Petition for Judicial Review filed
05/27/2020	Response to Petition filed
6/26/2020	Commission's Memorandum in Support of on the record Petition for Judicial Review
06/08/2020	Scheduling Order and Order for Mediation
06/29/2020	Order Vacating 6/8/2020 Order. Matter to proceed in normal course.
07/27/2020	Opposition and Response to Commission's Memorandum in Support of on the Record Judicial Review
08/11/2020	Commission's Reply to Opposition
11/02/2020	Hearing

CIRCUIT COURT FOR MONTGOMERY COUNTY, MARYLAND

Amica Mutual Insurance Company v. Montgomery County, Maryland, et al.

Case No. 483068-V (Tort)
(see also Ekaterina Uzylan Case No. – 483039-V)

Lead Counsel: Adams
Other Counsel:

Abstract: Subrogation suit for damages caused by a tulip poplar tree striking home.

Status: Complaint filed.

Docket:

08/06/2020	Complaint filed.
08/19/2020	Commission served.
09/08/2020	Plaintiff's Motion to Consolidate with Case 483039-V
09/18/2020	Defendant Montgomery County Maryland's Answer to Complaint
09/22/2020	Commission's Motion to Dismiss
09/22/2020	Commission's Motion to Consolidate with Case 483039-V
10/15/2020	Order of the Court Granting Motion to Consolidate. All future pleadings to be filed in case 483068V.

Concerned Citizens of Cloverly, et al. v. Montgomery County Planning Board

Case No. 483411-V (AALU)

Lead Counsel: Mills
Other Counsel:

Abstract: Judicial Review of Montgomery County Planning Board's approval of RCCG Jesus House Preliminary Plan 120160040

Status: Petition filed.

Docket:

09/10/2020	Petition for Judicial Review filed
10/01/2020	Planning Board's Response to Petition for Judicial Review filed
10/09/2020	RCCG Jesus House DC's Response to Petition filed

Dana v. Lenk, et al.
Case No. 482474-V (Tort)

Lead Counsel: Harvin
Other Counsel:

Abstract: Plaintiff disputes the existence of, and access to, a right-of-way utilized by an adjacent property owner.

Status: Amended Complaint filed.
Docket:

06/17/2020	Complaint filed
07/28/2020	Defendant Lenk's Motion to Dismiss
07/30/2020	Opposition to Motion to Dismiss
08/06/2020	Defendant Lenk's Reply to Plaintiff's Opposition to Motion to Dismiss
10/13/2020	Motion to Dismiss granted in part and denied in part
10/21/2020	Defendant Lenk's Answer to Complaint
10/22/2020	Amended Complaint filed.
10/29/2020	Commission served

HMF Paving Contractors Inc. v. Maryland-National Park and Planning Commission
Case No. 481768-V (CD)

Lead Counsel: Dickerson
Other Counsel: Johnson

Abstract: Construction suit alleging failure to pay two pay applications.

Status: Motion filed.

Docket:

04/30/2020	Complaint filed
08/28/2020	Motion to Dismiss filed
09/24/2020	Opposition to Motion to Dismiss
11/19/2020	Motions hearing

HMF Paving Contractors Inc. v. Maryland-National Park and Planning Commission
Case No. 483255-V (CD)

Lead Counsel: Adams
Other Counsel:

Abstract: Construction suit alleging failure to pay final payment.

Status: In discovery.

Docket:

08/25/2020	Complaint filed
10/16/2020	Commission served

Jan A.J. Bove, et al. v. Montgomery County Planning Board

Case No. 480775-V (AALU)

Lead Counsel: Sorrento

Other Counsel:

Abstract: Judicial Review of Montgomery County Planning Board's approval of 7025 Longwood Drive subdivision no. 620190100.

Status: Awaiting oral argument.

Docket:

03/09/2020	Petition for Judicial Review filed
03/18/2020	Commission's Response to Petition filed
11/06/2020	Oral argument

Kosary v. Montgomery County Planning Board

Case No. 476283-V (AALU)

Lead Counsel: Sorrento

Other Counsel:

Abstract: Judicial Review of Montgomery County Planning Board's approval of Primrose School Preliminary Forest Conservation Plan CU-18-08.

Status: Case stayed.

Docket:

12/06/2019	Petition for Judicial Review filed
12/11/2019	Planning Board's Motion to Dismiss filed
12/12/2019	Response to Petition for Judicial Review filed
12/19/2019	Petitioner's Supplemental Petition for Judicial Review filed
12/23/2019	Petitioner's Response to Motion to Dismiss filed.
01/21/2020	Motion to Dismiss denied as moot.
01/22/2020	Plaintiff's Motion for Stay and Request for Hearing.
02/06/2020	Primrose School Opposition to Motion to Stay.
02/28/2020	Motion for Stay Granted
03/03/2020	Case stayed pending resolution from County Hearing Examiner
03/26/2020	Plaintiff's interim report on status of administrative proceedings

Shipkovitz v. Montgomery County Planning Board

Case No. 483442-V (AALU)

Lead Counsel: Coleman
Other Counsel:

Abstract: Petition for Judicial Review of Planning Board Approval of 12500 Ardennes Avenue Site Plan820200080

Status: Petition for Judicial Review filed.

Docket:

09/15/2020	Petition for Judicial Review filed.
09/28/2020	Planning Board's Response to Petition filed.
10/26/2020	Ardennes Partners, LLC's Response to Petition filed.
10/26/2020	Ardennes Partners, LLC's and Planning Board's Joint Motion to Dismiss Petition for Judicial Review

Structural Engineering Group Inc. v. Maryland-National Capital Park and Planning Commission

Case No. 483234-V (CD)

Lead Counsel: Dickerson
Other Counsel: Johnson

Abstract: Construction change order dispute and time delay claim related to greenhouse at Brookside Gardens.

Status: Motions pending.

Docket:

08/21/2020	Complaint filed.
08/31/2020	Commission served.
09/29/2020	Motion to Dismiss or in the Alternative for Summary Judgment filed.
10/09/2020	Opposition to Motion to Dismiss filed.
12/09/2020	Motions hearing

Uzlyan v. Montgomery County, Maryland, et al.

Case No. 483039-V (Tort)
(see also Amica case, Case No. 483068-V)

Lead Counsel: Adams
Other Counsel:

Abstract: Personal injuries matter as a result of a tulip poplar tree striking a home.

Status: Case Consolidated with Case No. 483068-V.

Docket:

08/03/2020	Complaint filed.
08/19/2020	Commission served.
09/08/2020	Plaintiff's Motion to Consolidate with Case No. 483068-V
09/22/2020	Commission's Motion to Dismiss
09/22/2020	Commission's Motion to Consolidate with Case No. 483068-V
10/15/2020	Order of the Court Granting Motion to Consolidate. All future pleadings to be filed in case 483068V.

CIRCUIT COURT FOR PRINCE GEORGE'S COUNTY, MARYLAND

6525 Belcrest Road, LLC v. Dewey, L.C., et al.

Case No. CAE 20-11589 (AALU)

Lead Counsel: Dickerson
Other Counsel: Harvin

Abstract: Declaratory Action filed over a dispute involving a parking parcel. Plaintiff contends that Defendants have misconstrued prior approvals of the Planning Board regarding the need for parking in a manner that will harm their interests. Plaintiff seeks to enjoin the Planning Board from approving a Detailed Site Plan.

Status: Motions pending.

Docket:

04/14/2020	Complaint filed
06/05/2020	Commission served
07/06/2020	Answer filed by Commission
07/21/2020	Motion to Dismiss filed by Defendant Dewey, L.C.
07/23/2020	Motion to Dismiss filed by BE UTC Dewey Parcel, LLC
08/20/2020	Opposition to Motion to Dismiss
09/14/2020	Defendant, Dewey, L.C.'s Reply Response in Support of its Motion to Dismiss or Stay and Request for hearing
09/16/2020	Defendant, BE UTC Dewey Parcel, LLC's Reply in Support of Motion to Dismiss and Request for hearing
10/22/2020	Motions Hearing continued
10/26/2020	Defendants Dewey, L.C. and Bald Eagle Partners, Inc. Line Requesting Judicial Notice of Arbitrator's Decision
12/11/2020	Motions hearing

Alexander v. Proctor
Case No. CAL19-37187 (Tort)

Lead Counsel: Adams
Other Counsel:

Abstract: Alexander filed complaint against Park Police officer arising from arrest on Commission property.

Status: In discovery.

Docket:

11/20/2019	Complaint filed
12/06/2019	Proctor served
12/09/2019	Commission served
01/03/2020	Commission's Motion to Dismiss filed
01/23/2020	Motion to Dismiss denied. Plaintiff to file Amended Complaint on or before 02/07/2020.
02/08/2020	Amended Complaint filed
02/21/2020	Motion to Strike Amended Complaint or in the alternative to Dismiss
03/09/2020	Opposition to Motion to Strike
03/27/2020	Court orders matter to be set in for hearing on Motion
05/06/2020	Motion to Quash and for Protective Order
05/06/2020	Plaintiff's Opposition to Motion to Quash and for Protective Order
05/22/2020	Order of Court – Motion to Quash and for Protective Order held in abeyance
06/19/2020	Motions Hearing postponed due to COVID-19
09/16/2020	Motions Hearing
9/23/2020	Order of Court – Motion to Strike or in the alternative Motion to Dismiss denied. Motion to Quash and for Protective Order moot. Case to continue to due course.
9/30/2020	Answer to Amended Complaint filed.

Brown v. City of Bowie
Case No. CAL19-35931 (Tort)

Lead Counsel: Harvin
Other Counsel:

Abstract: Injuries resulting from an event at Trap and Skeet location owned by the Commission.

Status: 2nd Amended Complaint filed .

Docket:

11/15/2019	Complaint filed
01/27/2020	Defendant City of Bowie's Motion to Dismiss or in the Alternative for Summary Judgment
02/05/2020	Summons reissued for Commission
02/13/2020	Opposition to City of Bowie's Motion to Dismiss
02/26/2020	Defendant Daughtery's answer filed
03/13/2020	Commission served
04/08/2020	Commission's Answer filed
05/15/2020	Motions Hearing on City's Motion to Dismiss – continued due to pandemic
09/17/2020	Motions Hearing
9/18/2020	Amended Complaint and Jury Trial
9/21/2020	Second Amended Complaint
9/24/2020	Hearing on Defendant City of Bowie's Motion to Dismiss and/or Summary Judgment. Motion to Dismiss is denied. Motion for Summary Judgment is granted as based upon governmental immunity.

Coakley & Williams Construction v. Commission
Case No. CAL20-13593 (CD)

Lead Counsel: Adams
Other Counsel: Dickerson

Abstract: Breach of contract regarding work done at the Southern Area Aquatics Recreation Center.

Status: Motions pending.

Docket:

07/15/2020	Complaint filed
09/15/2020	Commission served
10/08/2020	Motion to Dismiss filed
10/27/2020	Opposition to Motion to Dismiss

Coe v. Commission
Case No. CAL19-39808 (ED)

Lead Counsel: Adams
Other Counsel:

Abstract: Coe filed for Judicial Review of decision to terminate employment following LEOBR police disciplinary hearing.

Status: Awaiting decision.

Docket:

12/13/2019	Petition for Judicial Review filed
01/03/2020	Commission's Response to Petition for Judicial Review
06/12/2020	Oral argument continued at Judge's request
08/7/2020	Oral argument held

Commission v. Batson
Case No. CAL19-24204 (WC)

Lead Counsel: Foster
Other Counsel:

Abstract: The Commission filed for Judicial Review on the record of WCC order regarding surgical authorization for leg causally related to accidental injury.

Status: Awaiting Trial.

Docket:

07/26/2019	Petition for Judicial Review filed
08/19/2019	Batson's Notice of Intent to Participate, Jury Demand
08/22/2019	Commission's Motion to Strike Request for De Novo Review and Request for Jury Demand
09/03/2019	Opposition to Motion to Strike filed
09/06/2019	Memo in Support of on the record Judicial Review filed
10/02/2019	Order of Court- Commission's Motion to Strike Request for De Novo Review and Request for Jury Trial denied. Case to proceed De Novo before a jury.
11/21/2019	Motion to Bifurcate filed by Commission in an attempt to litigate the dispositive legal issue preliminarily before any de novo trial.
12/16/2019	Motion to Bifurcate denied.
07/24/2020	Joint Motion for Continuance
08/21/2020	Order of Court; Joint Motion Granted. Trial set 4/6-7/2021
04/06/2021	Trial.

Getnet v. Maryland-National Capital Park and Planning Commission

Case No. CAL20-13268(Tort)

Lead Counsel: Harvin
Other Counsel: Johnson

Abstract: Tort suit for injuries allegedly sustained when visitor fell through decking at a historic property.

Status: Motions pending.

Docket:

07/06/2020	Complaint filed
07/29/2020	Commission served
08/20/2020	Motion to Dismiss filed
09/04/2020	Consent Motion for Extension of Time to File Opposition to Defendant's Motion to Dismiss
09/10/2020	Order of Court – Motion to Extend Time Granted
09/10/2020	Amended Complaint
09/11/2020	Opposition to Motion to Dismiss
09/22/2020	Amended Complaint
09/24/2020	Consent Motion for Extension of Time to File a Responsive Pleading to First Amended Complaint.
10/09/2020	Answer filed.

Gibson v. Commission

Case No. CAL 20-15318 (WC)

Lead Counsel: Foster
Other Counsel:

Abstract: Claimant seeks judicial review of an order from the Workers' Compensation Commission denying causal connection of back injury to the accidental injury of October 20, 2017.

Status: In discovery.

Docket:

09/03/2020	Petition for Judicial Review filed
09/18/2020	Response to Petition and Expert Designation

Heard v. Maryland-National Capital Park and Planning Commission

Case No. CAL20-14095(AALU)

Lead Counsel: Warner
Other Counsel: Goldsmith

Abstract: Judicial review of the Prince George's County Planning Board's approval of Preliminary Plan of Subdivision 4-05068 and denial of March 31, 2020, request for document under the Maryland Public Information Act.

Status: Petition for Judicial Review filed.

Docket:

07/30/2020	Petition filed
08/16/2020	Commission served
08/31/2020	Response to Petition for Judicial Review filed.

Jackson v. Prince George's County Sports & Learning Complex

Case No. CAL19-21516 (Tort)

Lead Counsel: Harvin
Other Counsel:

Abstract: Injury to a minor from use of equipment at the Sports & Learning Complex.

Status: In discovery.

Docket:

07/15/2019	Complaint filed
01/22/2020	Commission accepted service
01/27/2020	Complaint to be amended to reflect Commission as party.
02/04/2020	Amended Complaint filed
03/18/2020	Commission served
04/08/2020	Commission's answer filed.
09/02/2021	Trial

King v. Commission
Case No. CAL 19-30096 (WC)

Lead Counsel: Foster
Other Counsel:

Abstract: Claimant seeks judicial review of an order from the Workers' Compensation Commission denying authorization for neck surgery.

Status: Awaiting trial.

Docket:

09/23/2019	Petition for Judicial Review filed
10/03/2019	Commission filed response to Petition.
06/30/2020	Trial continued due to COVID-19
03/25/2021	Trial

Montague v. Newton White Mansion
Case No. CAL 20-05753 (Tort)

Lead Counsel: Harvin
Other Counsel:

Abstract: Slip and fall on ice at Newton White Mansion.

Status: In discovery.

Docket:

02/13/2020	Complaint filed.
06/19/2020	Amended Complaint filed.
07/21/2020	Answer filed.
09/15/2021	Trial.

Murray v. Commission
Case No. CAL 20-16372 (WC)

Lead Counsel: Foster
Other Counsel:

Abstract: Claimant seeks judicial review of an order from the Workers' Compensation Commission that held claimant is not permanently and totally disabled.

Status: In discovery.

Docket:

09/18/2020	Petition for Judicial Review filed
10/05/2020	Response to Petition for Judicial Review and Expert Designation
10/13/2020	Subsequent Injury Fund's Response to Petition for Judicial Review
10/13/2020	Subsequent Injury Fund's Cross-Petition for Judicial Review
10/21/2020	Claimant's Response to Cross-Petition
10/27/2020	Commission's Response to Cross-Petition

Newton, et al. v. Prince George's County Planning Board
Case No. CAL 20-15331(AALU)

Lead Counsel: Warner
Other Counsel: Goldsmith

Abstract: Petition for Judicial Review of Prince George's County Planning Board's approval of Preliminary Plan of Subdivision 4-19048.

Status: Petition filed.

Docket:

09/04/2020	Petition for Judicial Review filed
------------	------------------------------------

Pumphrey v. Wilson
Case No. CAL 19-30161 (Tort)

Lead Counsel: Dickerson
Other Counsel: Foster

Abstract: Automobile accident with vehicle driven by deceased former Commission employee.

Status: In discovery.

Docket:

09/16/2019	Complaint filed
07/24/2020	Motion to Dismiss
08/17/2020	Opposition to Motion to Dismiss and Request for Hearing.
09/02/2020	Order of Court – Motion to Dismiss Denied
09/18/2020	Answer filed
06/08/2021	Trial

Snyder v. State of Maryland, et al.
Case No. CAL20-13024 (Tort)

Lead Counsel: Adams
Other Counsel:

Abstract: Tort suit for injuries allegedly sustained when tennis player allegedly tripped in hole of divider net and broke clavicle.

Status: Amended Complaint filed.

Docket:

06/19/2020	Complaint filed.
07/27/2020	Commission's Motion to Dismiss
07/27/2020	Motion to Transfer Venue
08/07/2020	Consent Line to Extend Deadline to file Opposition to Motion to Dismiss
08/11/2020	Request for Hearing on Motion to Transfer Venue
08/11/2020	Opposition to Motion to Dismiss
08/25/2020	State of Maryland's Motion to Dismiss
08/26/2020	Consent to extend deadline for Plaintiff to file an Opposition to Motion to Dismiss
8/26/2020	Order of Court - Partial Line of Dismissal for Defendant, State of Maryland, only. Dismiss all claims with Prejudice.
9/10/2020	Amended Complaint.

Stewart v. P.G. Planning Board
Case No. CAL 20-11215 (AALU)

Lead Counsel: Goldsmith
Other Counsel:

Abstract: Judicial Review of Prince George's County Planning Board's approval of GB Mall Limited Partnership/Quantum Company Preliminary Plan Case No.4-19023

Status: Petition for Judicial Review filed.

Docket:

04/01/2020	Petition for Judicial Review filed
04/13/2020	Amended Petition for Judicial Review filed.
06/26/2020	Second Amended Petition filed.
07/20/2020	Response to Petition filed.

Wolf, et al. v. Planning Board of Prince George's County
Case No. CAL20-14895 (AALU)

Lead Counsel: Warner
Other Counsel: Goldsmith

Abstract: Judicial Review of the Prince George's County Planning Board's approval of Preliminary Plan of Subdivision 4-18001 (Magruder Pointe).

Status: Motions pending.

Docket:

08/19/2020	Petition for Judicial Review filed.
09/29/2020	Notice of Intent to Participate
09/29/2020	Motion to Dismiss filed by Werrlein WSSC, LLC
10/13/2020	City of Hyattsville's Notice of Intent to Participate
10/19/2020	Response to Petition for Judicial Review
10/19/2020	Planning Board's Motion to Dismiss filed

MARYLAND COURT OF SPECIAL APPEALS

Benton v. Woodmore Overlook Commercial, LLC

CSA-REG-2118-2019 (AALU)

(Originally filed under CAL19-14488 in Prince George's County)

Lead Counsel: Borden
Other Counsel: Goldsmith

Abstract: Judicial Review of decision of the Prince George's County Planning Board No. 19-32, File No. 4-180007.

Status: Petition for Writ of Certiorari filed.

Docket:

12/19/2019	Appeal filed
02/11/2020	Show Cause issued by Court regarding non-lawyer representing corporate entities
02/25/2020	Response to Show Cause filed
03/04/2020	Order of Court. Show Cause satisfied, appeal to proceed.
05/07/2020	Motion for Emergency Ex Parte Temporary Restraining Order Pending Appeal and Order to Show Cause Why a Preliminary Injunction Should Not Be Issued
05/13/2020	Commission's Response to Motion filed.
05/18/2020	Appellant's Motion for Leave & Notice of Intent to Respond to Commission's Opposition to Temporary Restraining Order Pending Appeal
05/26/2020	Appellant's Motion for Leave of the Maryland Rules Regard the Page Limit, Word Count, Content or Form of Appellant's Motion for Temporary, Preliminary and Permanent Injunction.
06/03/2020	Woodmore Overlook's Motion to Join in Commission's Opposition and Response to Appellant's Motion for Temporary Restraining Order and Preliminary Injunction.
06/04/2020	Order of the Court. Appellant's Motion's denied.
06/05/2020	Entry of Appearance of Peter Z. Goldsmith
06/23/2020	Appellant Brief and Record Extract filed
06/30/2020	Order – Appellee to refile brief in compliance with Maryland Rules by 8/28/2020
08/03/2020	Petition for Writ of Certiorari
09/01/2020	Motion to Extend Time to File Brief
09/03/2020	Opposition to Motion
09/04/2020	Appellant Brief and Record Extract
09/08/2020	Motion Reply
09/21/2020	Order of Court. Appellant's Motion granted in part. Appellee's brief due October 21, 2020.
10/13/2020	Appellant's Brief filed
10/21/2020	Appellee's Brief and Appendix filed

Benton v. Woodmore Overlook Commercial, LLC

CSA-REG-0707-2020 (AALU)

(Originally filed under CAL20-13237 in Prince George's County)

Lead Counsel: Warner
Other Counsel: Goldsmith

Abstract: Judicial Review of decision of the Prince George's County Planning Board on Preliminary Plan of Subdivision 4-18007, Woodmore Overlook Commercial.

Status: Appeal filed.

Docket:

09/09/2020	Appeal filed
09/30/2020	Entry of Appearance by Commission
10/27/2020	Motion to Dismiss

Estreicher v. Montgomery County Planning Board.

CSA-REG-0781-2020 (AALU)

(Originally filed under 472672-V in Montgomery County)

Lead Counsel: Mills
Other Counsel:

Abstract: Appeal of August 28, 2020 Order reversing Planning Board Resolution MCPB No 19-108 approving Sketch Plan 320190100 and remanding the matter to the Planning Board for further proceedings pursuant to the Court's findings.

Status: Appeal filed.

Docket:

09/28/2020	Appeal filed
10/30/2020	Order to Proceed

Gaspard v. Montgomery County Planning Board
CSA-REG-0579-2019 (AALU)

Lead Counsel: Mills
Other Counsel:

Abstract: Judicial review of decision affirming Planning Board's approval of Preliminary Plan 120160180 Glen Mill – Parcel 833

Status: Affirmed.

Docket:

05/23/2019	Appeal filed
06/03/2020	Oral Argument
10/29/2020	Opinion and Order of Court. Judgment of the Circuit Court for Montgomery County Affirmed

MARYLAND COURT OF APPEALS

Benton v. Woodmore Overlook Commercial, LLC
COA-PET-0199-2020 (CSA-REG-2118-2019) (AALU)
(Originally filed under CAL19-14488 in Prince George's County)

Lead Counsel: Borden
Other Counsel: Goldsmith

Abstract: Judicial Review of decision of the Prince George's County Planning Board.

Status: Petition denied.

Docket:

08/03/2020	Petition for Writ of Cert. filed
08/13/2020	Order on Motion Denied
08/18/2020	Line filed
08/18/2020	Respondent Answer
10/23/2020	Petition denied.

U.S. DISTRICT COURT OF MARYLAND

Evans v. Commission, et al.
8:19-cv-02651 TDC (ED)

Lead Counsel: Dickerson
Other Counsel: Foster

Abstract: Plaintiff, police lieutenant, filed a complaint against the Commission and four individual defendants, alleging discrimination, retaliation and assorted negligence and constitutional violations.

Status: Complaint filed.

Docket:

09/11/2019	Complaint filed
10/23/2019	Notice of Intent to file Motion for More Definite Statement filed by Defendants Commission, McSwain, and Riley
10/24/2019	Notice of Intent to file Motion for More Definite Statement filed by J. Creed on behalf of Defendant Murphy
10/28/2019	Notice of Intent to File a Motion for More Definite Statement filed by attorney C. Bruce on behalf of Defendant Uhrig
11/19/2019	Case Management Conference held
11/20/2019	Order directing Plaintiff's Counsel to file Status Report by November 26, 2019
11/26/2019	Status Report filed by Plaintiff agreeing to file Amended Complaint specifying against whom each claim is asserted and dates of alleged events.
12/10/2019	Amended Complaint filed.
12/23/2019	Notice of Intent to file a Motion to Dismiss filed by all defendants
12/30/2019	Case Management conference held
01/09/2020	Order granting Plaintiff leave to file Amended Complaint
01/16/2020	Second Amended Complaint filed
02/14/2020	Joint Motion to Dismiss filed by all Defendants
03/20/2020	Opposition to Motion to Dismiss
03/20/2020	Motion for Leave to file Third Amended Complaint
03/20/2020	Third Amended Complaint
03/25/2020	Order of Court directing Defendants to file Opposition no later than April 3, 2020.
04/03/2020	Opposition to Leave to file Third Amended Complaint
04/17/2020	Plaintiff's Reply to Defendants' joint Opposition to Plaintiff's Motion for Leave to file Third Amended Complaint.

05/07/2020	Order granting Motion for Leave to File Third Amended Complaint; denying as moot Defendants' Joint Motion to Dismiss; granting defendants leave to renew their Joint Motion to Dismiss by May 22, 2020.
06/05/2020	Joint Motion to Dismiss for Failure to State a Claim filed by Commission, McSwain, Murphy, Riley and Uhrig.
07/10/2020	Motion for Leave to File Excess Pages
07/16/2020	Order granting in part and denying in part Motion for Leave to file Excess Pages and directing the Plaintiff to file a brief by 7/23/2020
07/23/2020	Response in Opposition to Joint Motion to Dismiss for Failure to State a Claim
08/06/2020	Response to Motion for Leave to file Excess Pages.
08/06/2020	Reply to Opposition to Joint Motion to Dismiss.